



Movirack Mobile Pallet Racking

Large-scale storage on mobile shelving units





General Features of Movirack System

With the Movirack system, shelving units become more compact and their storage capacity considerably increased, particularly when using pallets. All this without giving up direct access to any item in stock.

The shelving units are installed over guided mobile bases that slide laterally, thus eliminating the need for aisles, which open up only when accessed.



The operator gives the order to automatically open the unit, either by remote control or manually by flicking a switch.

The mobile bases have motors, sliders, electronics and several safety systems to guarantee a safe, efficient operation.

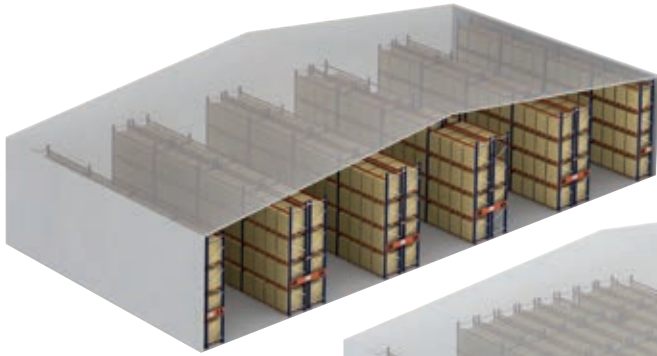

Warehouse using conventional pallet storage.

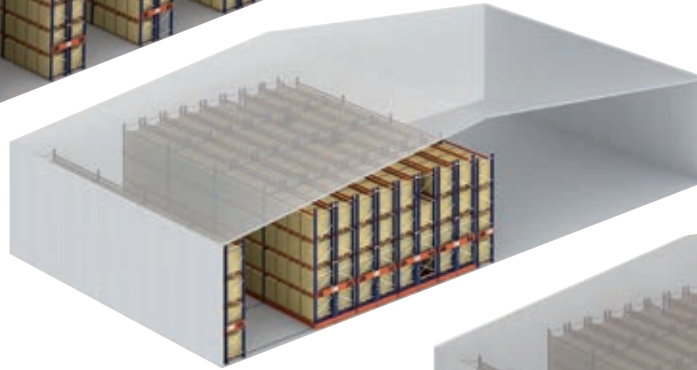

Warehouse using mobile bases. The same capacity with a single aisle occupies less space.

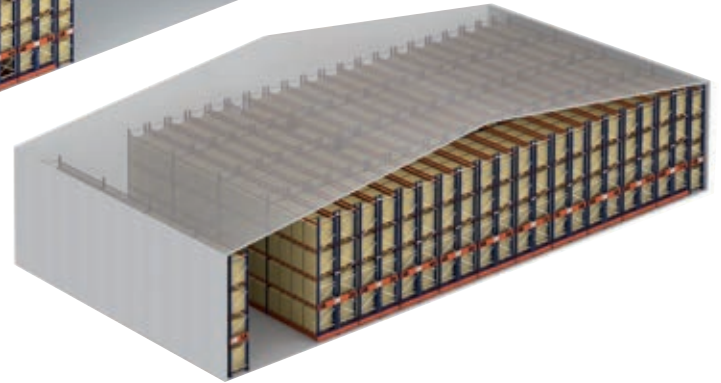

Warehouse using mobile bases. Utilizing the most space possible considerably increases storage capacity.

Most Outstanding Advantages

Direct access to any pallet in storage

As these shelving units are installed over bases, merely by opening up the corresponding aisle provides direct access to the desired pallet.

Makes the most of your available space

This excellent utilization of available space is thanks to two basic premises: increasing the storage capacity and reducing the storage area to build.

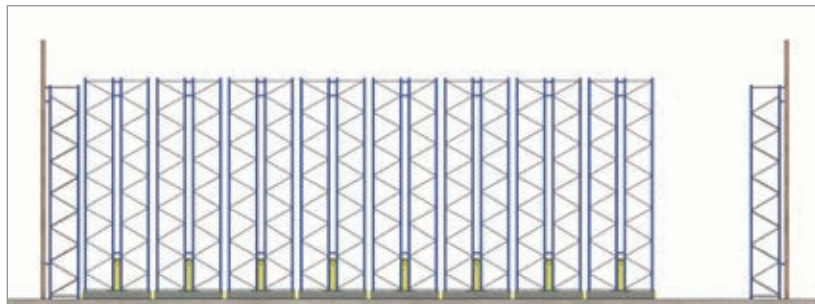

Example of a pallet warehouse using mobile bases.

This figure illustrates the sizeable increase in capacity that a mobile base system provides (from 80% to 120% more than a conventional pallet system. The increase depends on the type of forklift being used, the facility size and the number of open aisles.

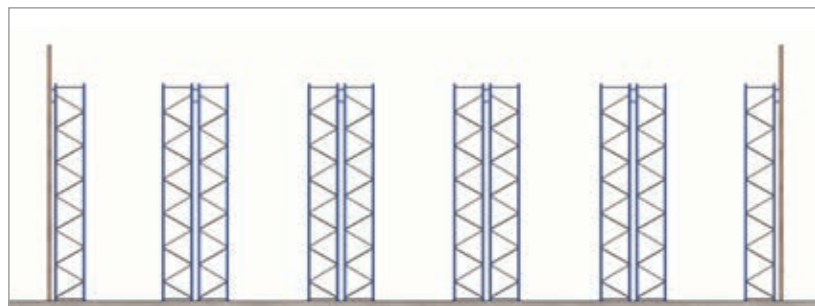

Example of a conventional pallet warehouse.



Applications

Here we can see some examples of its multiple applications:

Palletized product storage

- General storage,
- products with average or low-level rotation,
- refrigerated storerooms,
- intermediary or shipping warehouses.





Warehouse with cantilever shelves

- For sheets, reels, and large or irregular-sized products.

In these cases, the same utilization criteria for palletized products is applied.

Conventional forklifts can be used (reach trucks) alternatively ones specially used for lengthy products (lateral load or four-way fork lifts).

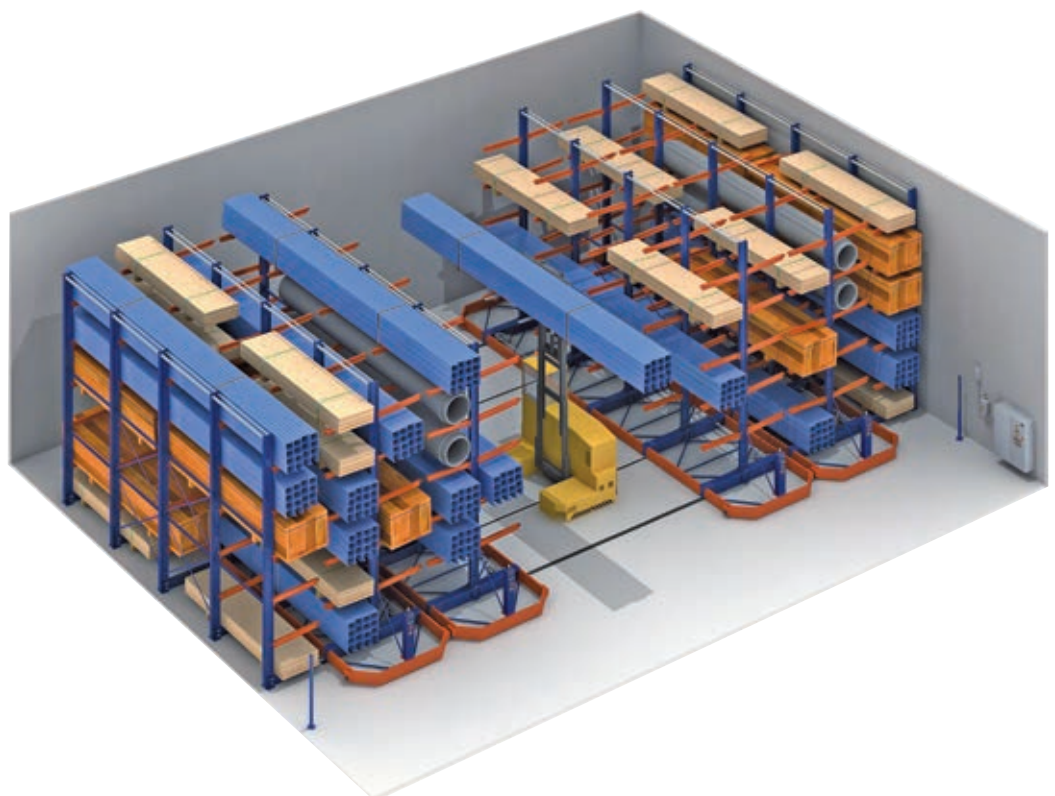

Refrigerated Storerooms

The Movirack System is ideal for low or medium-height refrigerated or freezer storerooms, as:

- Being a compact system, its investment is quickly recovered.
- Every pallet can be directly accessed: very useful when there are few pallets per item.
- The energy savings are increased in terms of generating cold air. The air is spread over a larger number of pallets in storage, thus reducing the expense per pallet.
- There is better air circulation in down times when using the parking option, which increases the separation between shelves to spread the aisle space more equidistantly.
- With the parking option, if enough space is available, aisles can be used to pick individual items from the lower shelves.
- The use of a conventional forklift allows for direct access from the dock area to different points on the shelving unit.

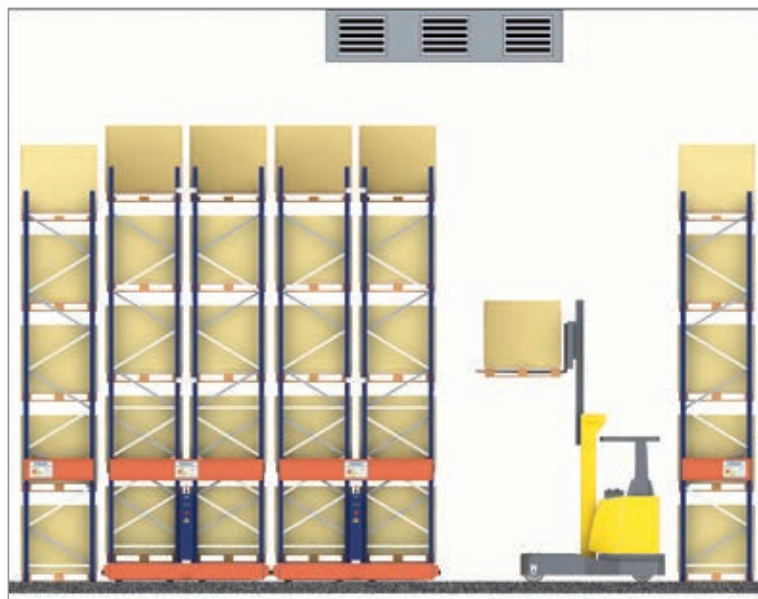

Option with a single open aisle.

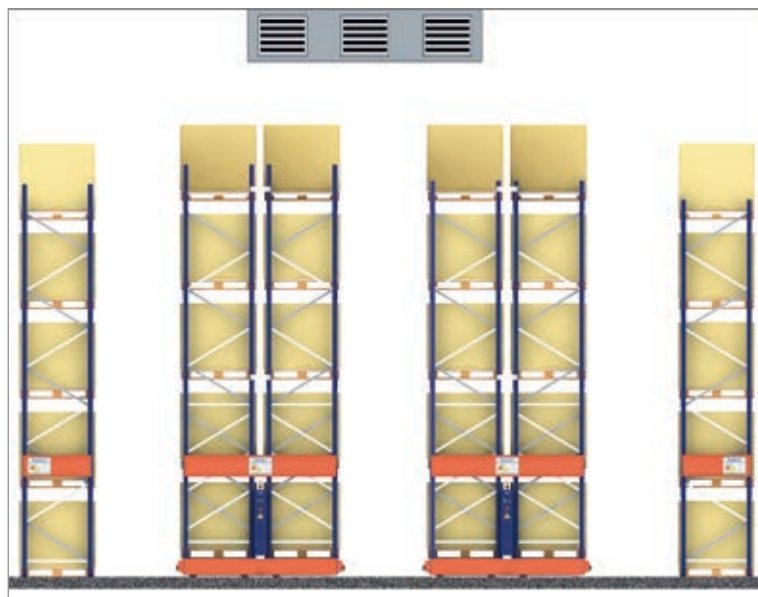

Option parking.

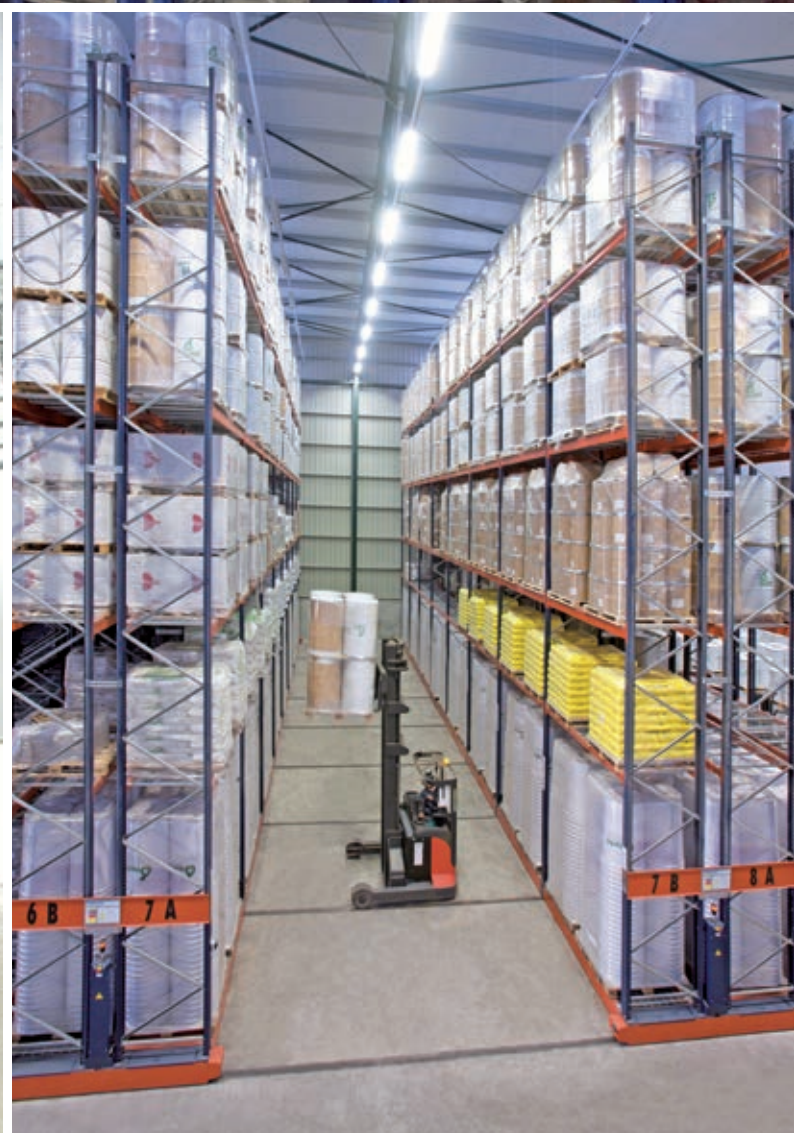

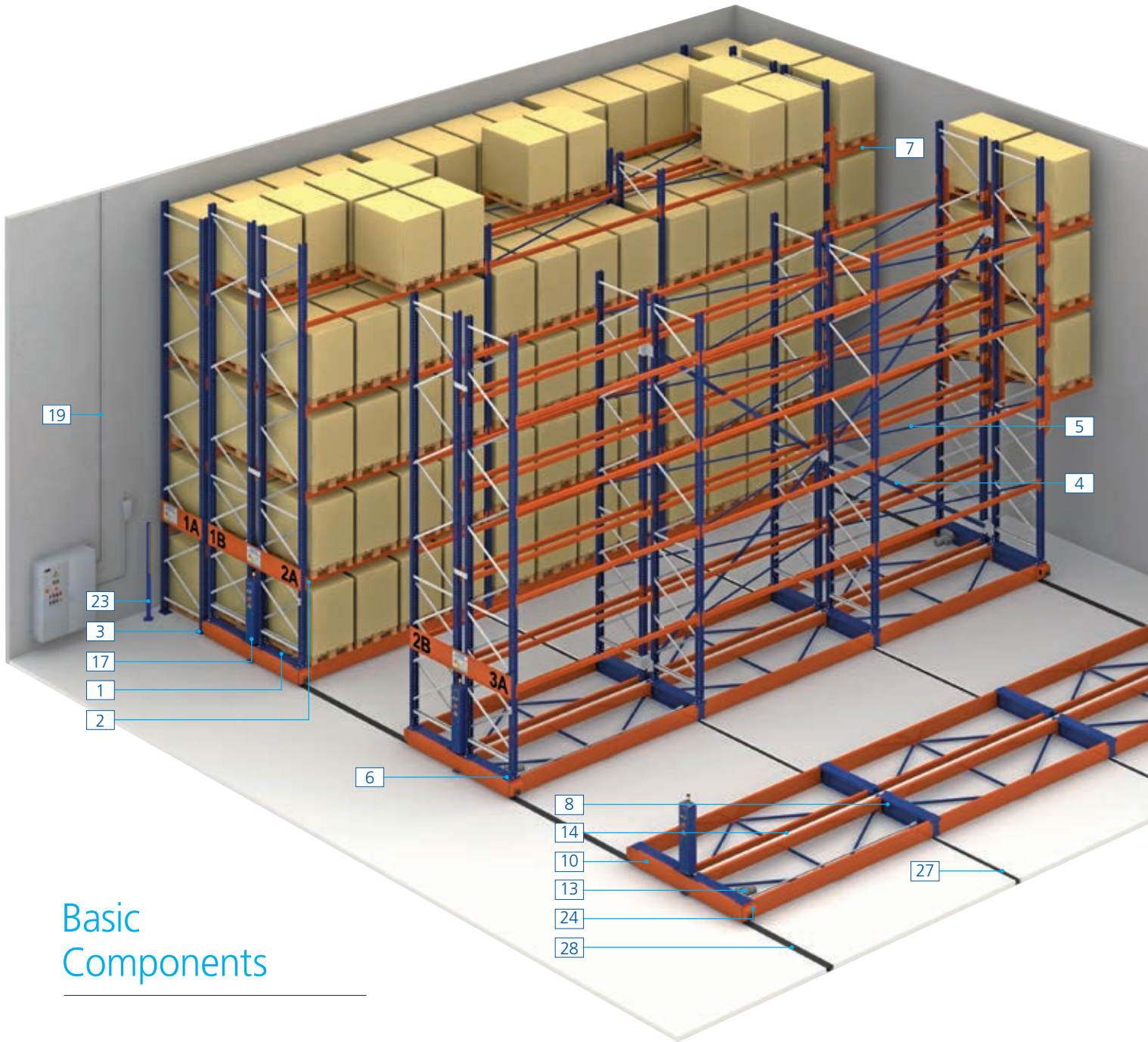

Basic Components

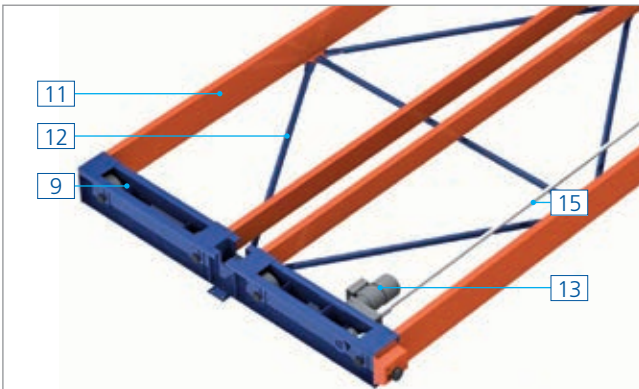

Shelves

1. Chassis
2. Girder and mechanical safety lock
3. Anchorage and fasteners
4. Vertical brace
5. Horizontal brace
6. Base fasteners
7. Brackets (optional)

Mobile bases

8. Carrier roller/Carrier driver
9. Carrier guide
10. Carrier end
11. Base girder
12. Rigidity bracing
13. Motor
14. Cable channel
15. Drive shaft

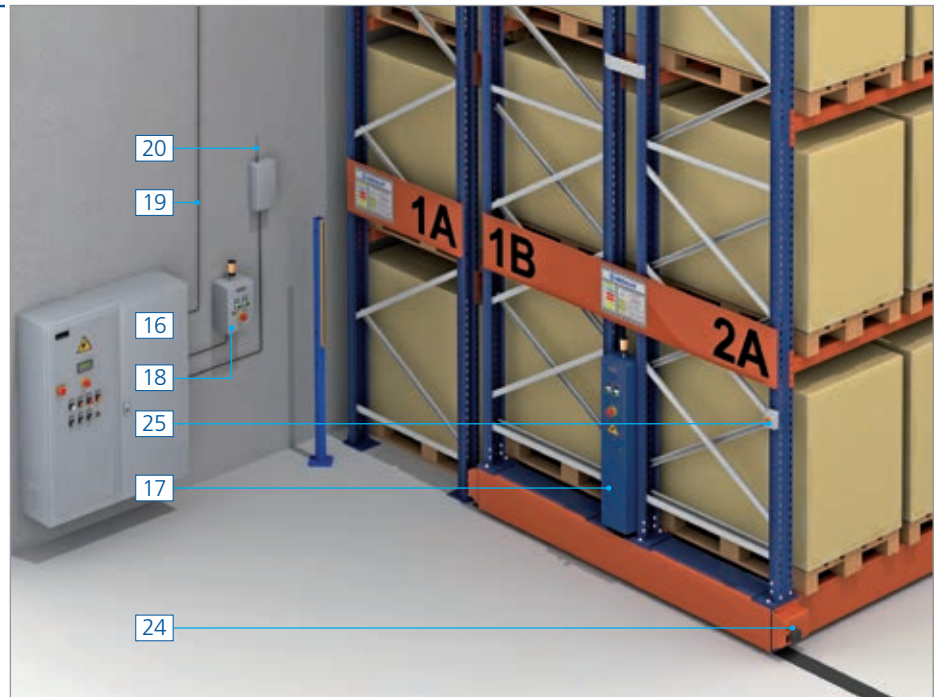

Safety and control parts

16. Exterior main power panel
17. Remote power panel
18. Parking panel
19. Signal and power cables
20. Remote control antenna
21. Remote control
22. Control button pad
23. Exterior safety barrier
24. Interior safety barrier and proximity photocell
25. Reset button
26. Emergency button

Built-in tracks

27. Roller tracks
28. Guide track

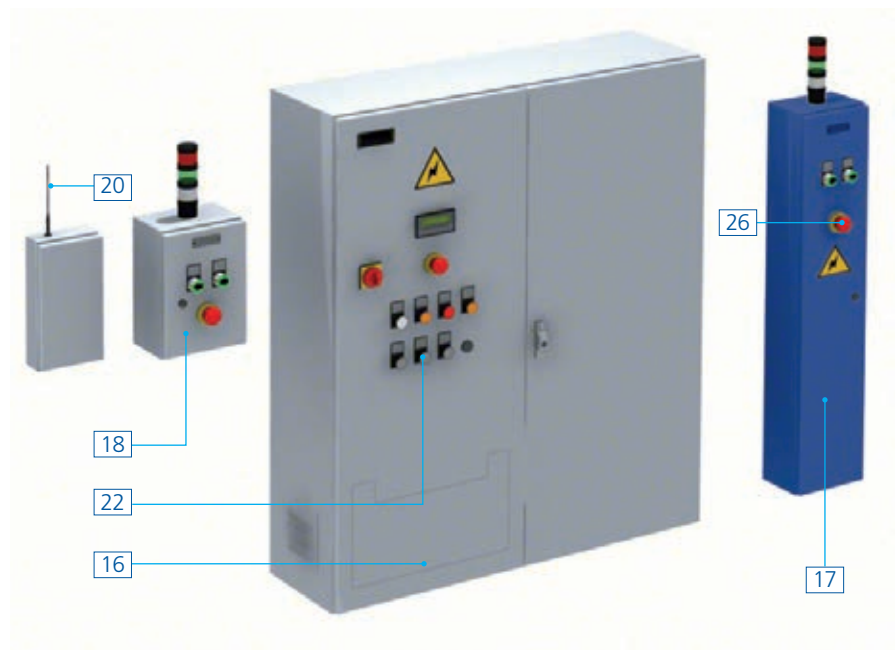



Building Systems

Built-in tracks

The moving shelving units travel over tracks which first have been leveled, fastened together and then sunk into the floor.

There are smooth tracks and guide tracks that match to the wheels on the carrier. The number of tracks depends on the characteristics of each facility.

They can be installed in many different ways.

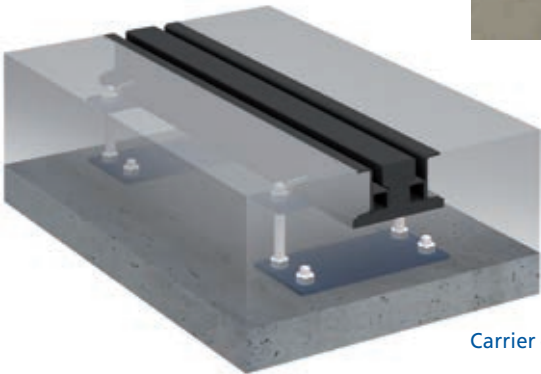

Carrier guide.

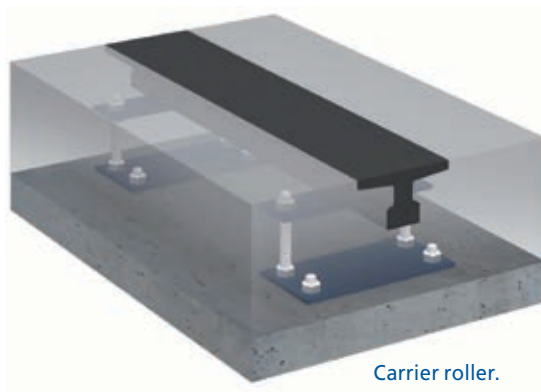

Carrier roller.

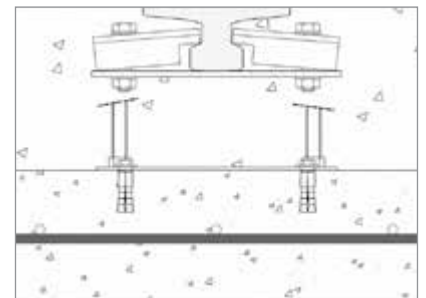

Over a concrete subfloor. This system is most often used over a newly built floor.

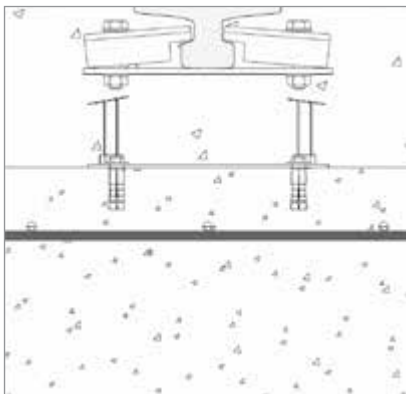

Over an existing floor with channels and spreader beams. Appropriate when the floor resistance is insufficient or undetermined.

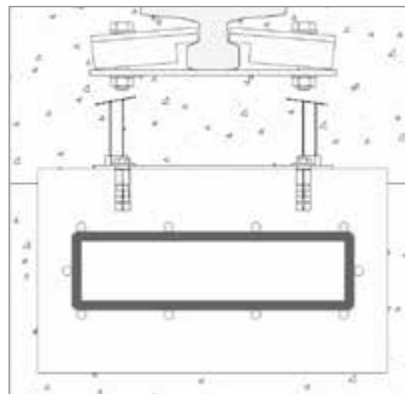

Over an existing floor with posterior fill. Appropriate when the floor has adequate resistance but new flooring is to be laid.

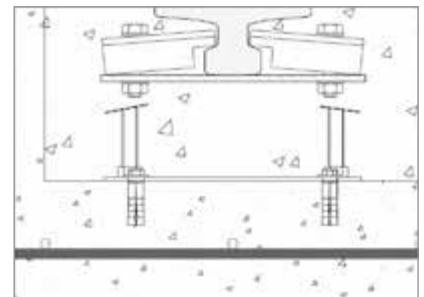

Over an existing floor with channels. Valid when the floor can handle the units without compromising its resistance.



Shelves

Facilities tend to be formed by fixed shelving units with access either on one side or both sides, or by mobile shelving units that always have access on both sides.

Both types have structural systems that are the same as convention pallet shelving units.

However, mobile shelving units must be equipped with rigidity bracing that provide them with better stability to withstand the forces produced by starting and stopping their movement.

There can be levels set for two, three or four pallets, depending on the size and load to be stored.

This figure shows the measurements and tolerance allowed in the direction of displacement.

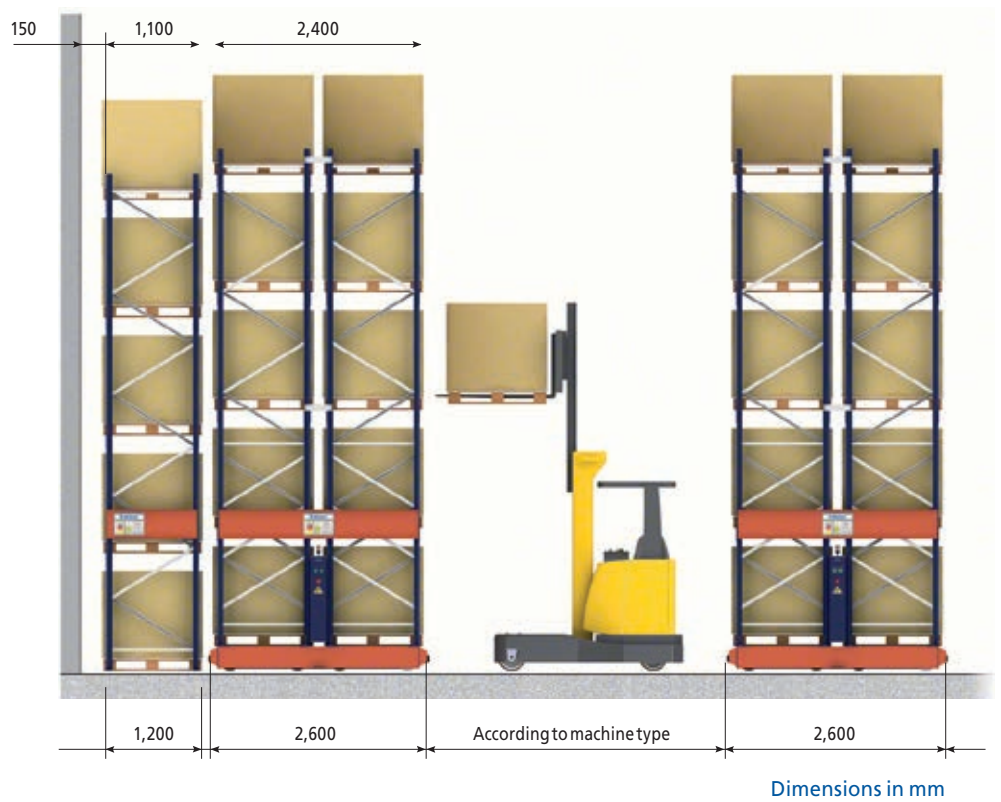

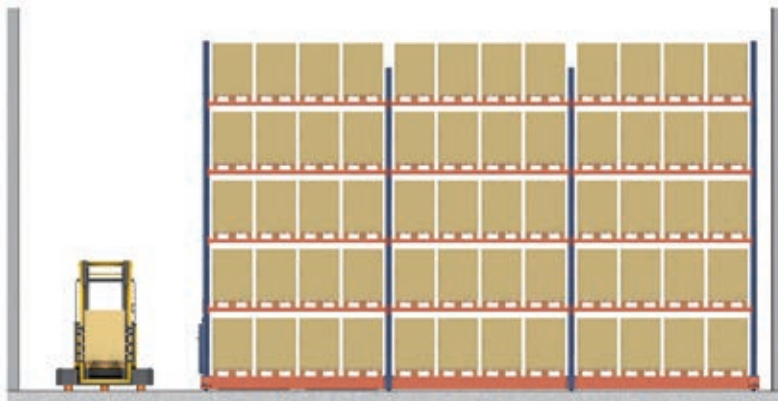
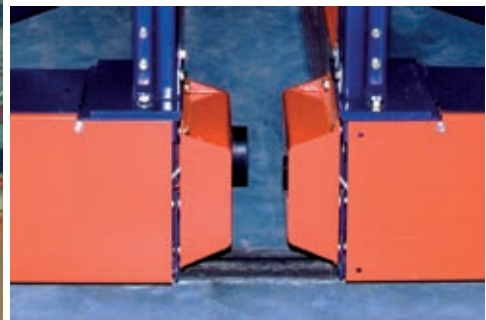

One-side access aisle

Most facilities require a single main aisle to maneuver in, so the shelving units are located perpendicular to it with a minimum distance from the sidewalls of 200 mm.

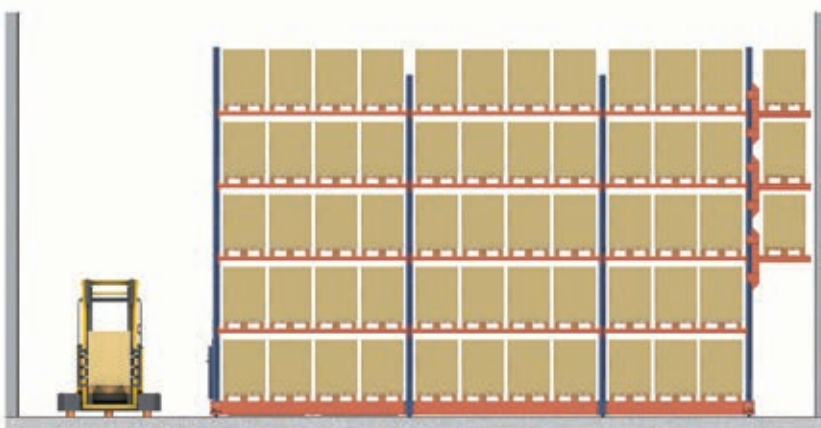

Access aisle plus pedestrian walkway

When necessary, or for safety reasons, the module closest to the wall can be cantilevered to leave the space below free for a pedestrian walkway or a fire escape route.

Basic Components for Cantilevered Shelving Units

The structural system, guides and embedment systems, in addition to operational criteria and tolerance factors, are similar to facilities with palletized shelving units.

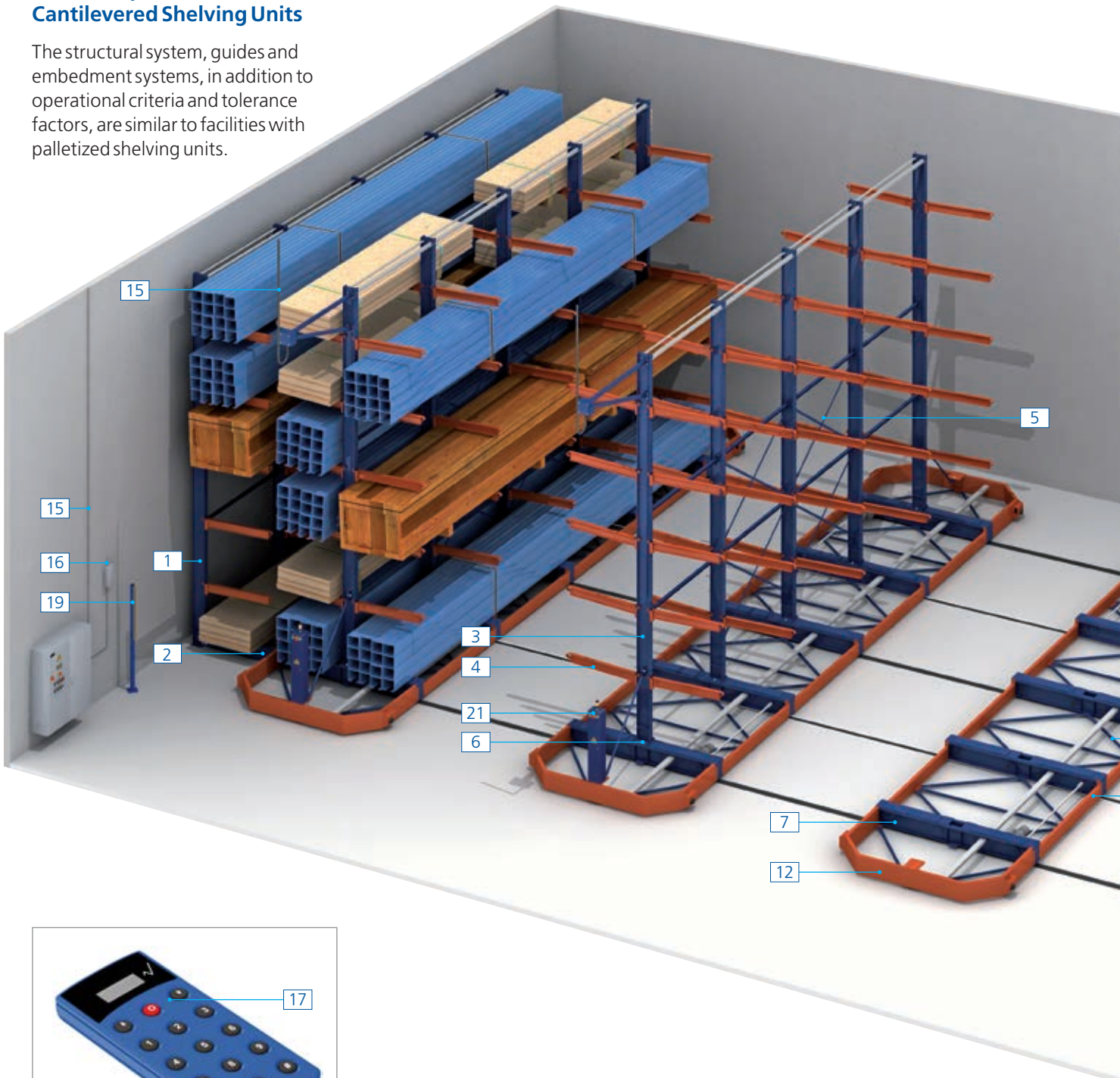

Shelves

1. Single deep column
2. Cantilever baser
3. Double deep column
4. Cantilever arm
5. Set of vertical braces
6. Anchorage or fasteners

Mobile bases

7. Carrier roller / drive carrier
8. Base girder
9. Rigidity bracing
10. Motor
11. Cable channel
12. Set of base brackets

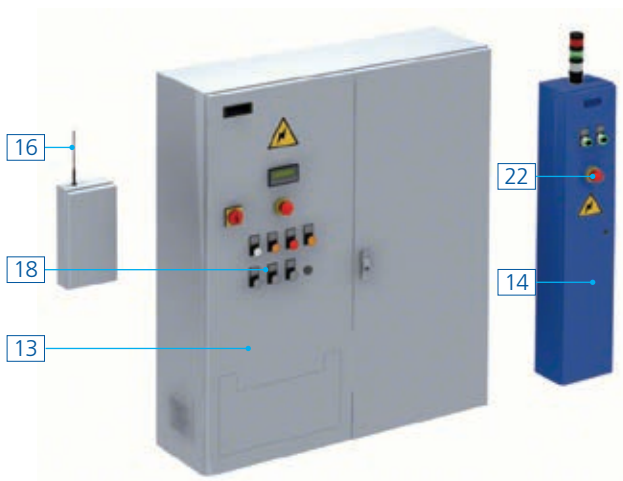
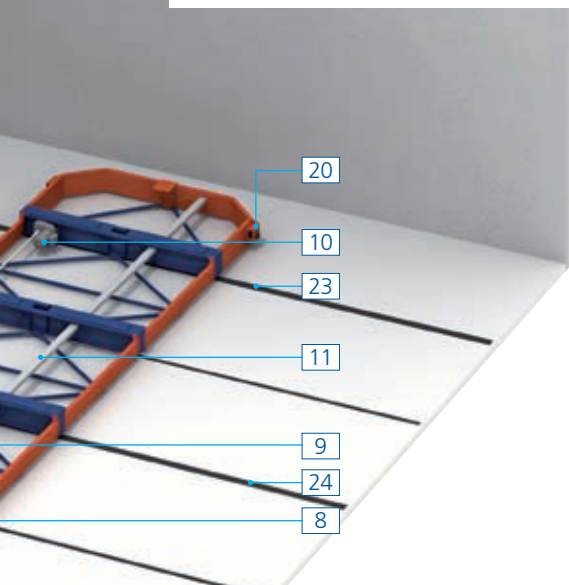
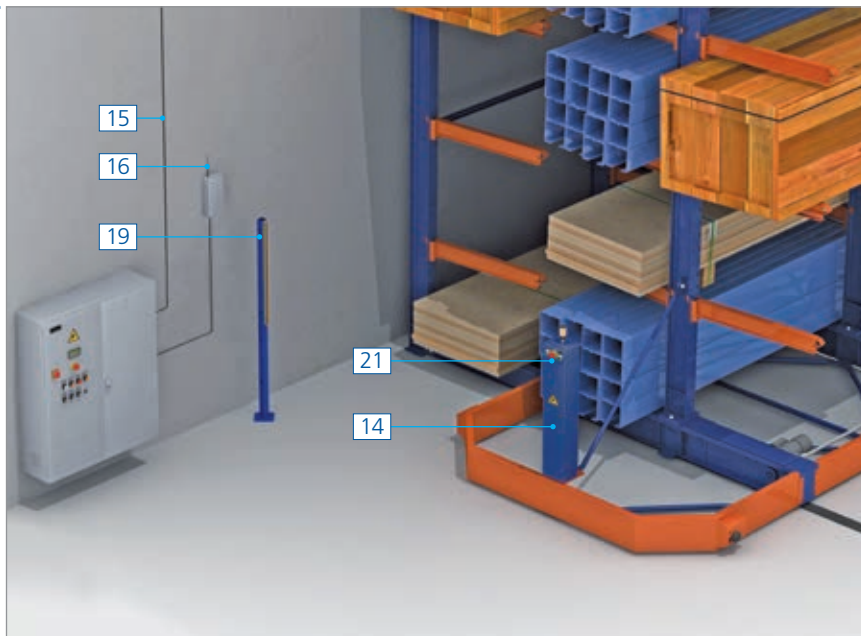

Safety and control parts

13. Exterior main power panel
14. Remote power panel
15. Signal and power cables
16. Remote control antenna
17. Remote control
18. Control button pad
19. Exterior safety barrier
20. Interior safety barrier and proximity photocell
21. Reset button
22. Emergency button

Built-in tracks

23. Roller tracks
24. Guide track





Exterior safety barrier

Controlling the Facility

The basic features of the control system are found in the main power panel and the remote power panel. These ensure the mobile shelving units move safely and automatically.

The principal control features found in the panel are:

- The PLC controller, the brains behind the facility and where the operational logic is programmed.
- Power converters (synchronize the operations of the different motors on the base, which provide a boost of acceleration and a smooth stop). These also lengthen the lifespan of several different components (motors, wheels, guides, etc.).
- Error control screen.
- Aisle lighting panel (optional).



Remote control

Controls opening/closing and can reset the system without having to get down from the forklift.

Safety devices

The many built-in safety devices conform to current safety standards and guarantee the mobile equipment are operated safely. Some of these include:

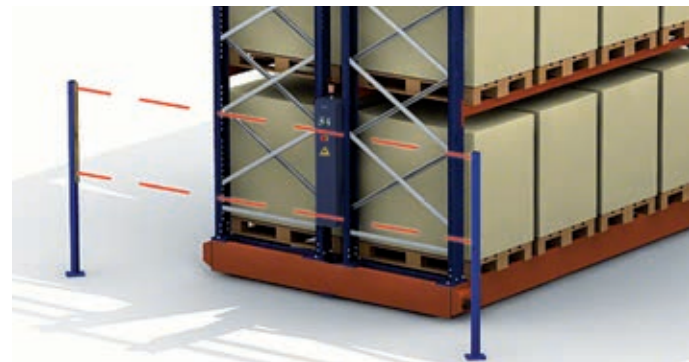

Exterior safety barrier

When open during operations in the aisle, anyone passing through the work aisle, either on foot or in the forklift, will automatically cut the power to the shelving units, impeding their movement.

It can only be reset manually by pressing the reset button located at the top of the aisle or by remote control, once the safety protocol has been applied.

This ensures that there are no operators working inside.

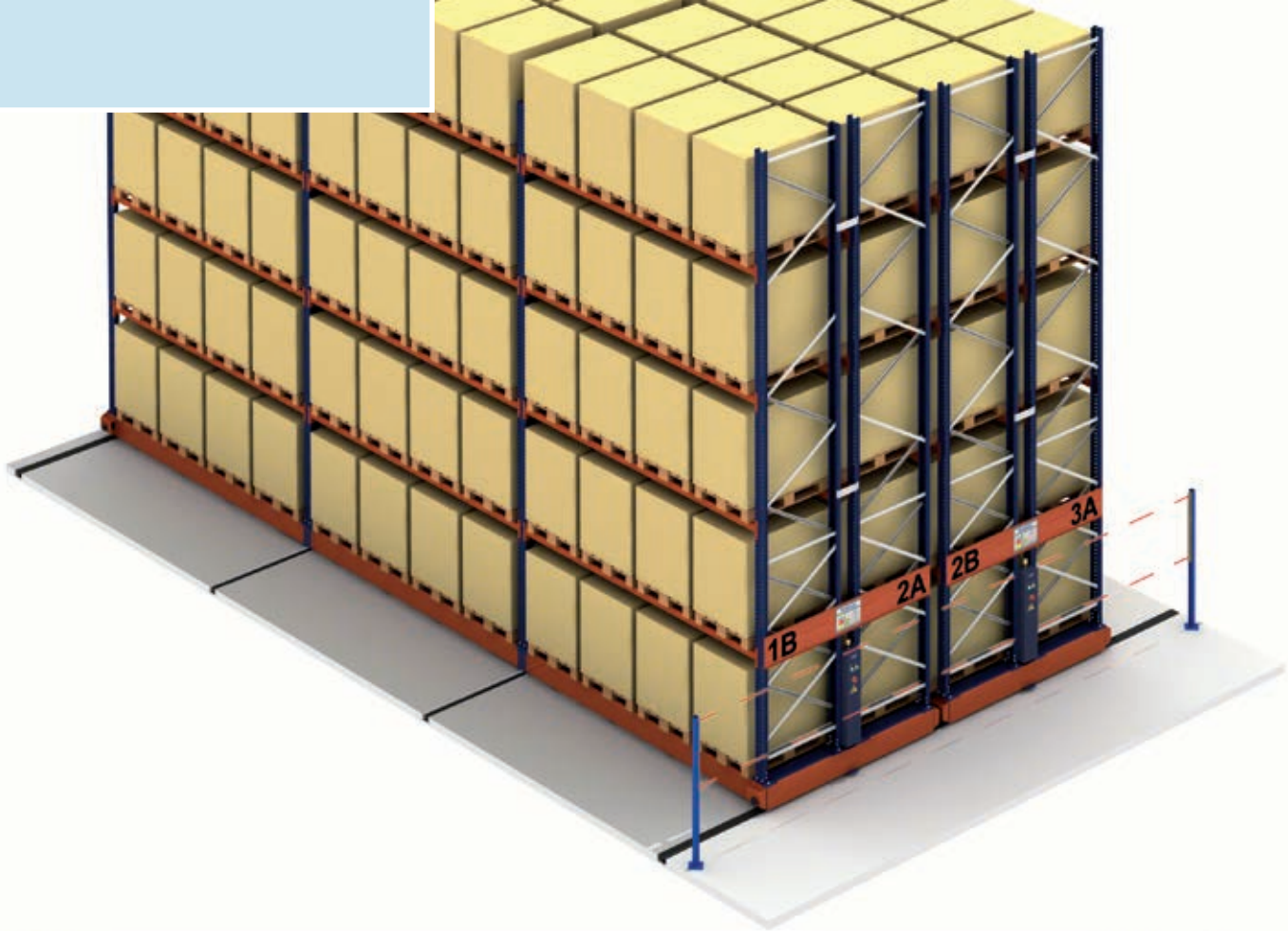

Interior safety barrier

On either side of the bases are longitudinal optic safety barriers which cover the entire front of the mobile shelving unit. In event of an emergency, the bases can be stopped if the beam of light is interrupted, with your foot for example. What's more, this barrier detects the presence of foreign objects in the aisle which may impede safe operation.

Proximity photocell

This ensures a smooth, safe stop at the pre-programmed separation distance.



Reset buttons

These are located at the top of the aisle.



Emergency buttons

These are located in the remote power box and can stop the moving shelves in an emergency.



Easy WMS Warehouse Management Software

The nerve centre of the installation



Easy WMS is a warehouse management software (WMS) developed and constantly updated by the Mecalux Software Solutions division, comprising more than 100 full time engineers.

Easy WMS ensures correct operation and control of installations, coordinating the movement of goods from origin to destination to achieve maximum efficiency. It also handles full warehouse operations to integrate with customer systems, because it has standard communication interfaces with the leading ERPs on the market.

To facilitate integration of the software in warehouses of every kind and size, Easy WMS has several modules that provide great flexibility and a high degree of customisation. It offers two types of architecture: cloud-based. (SaaS) and on-premises.

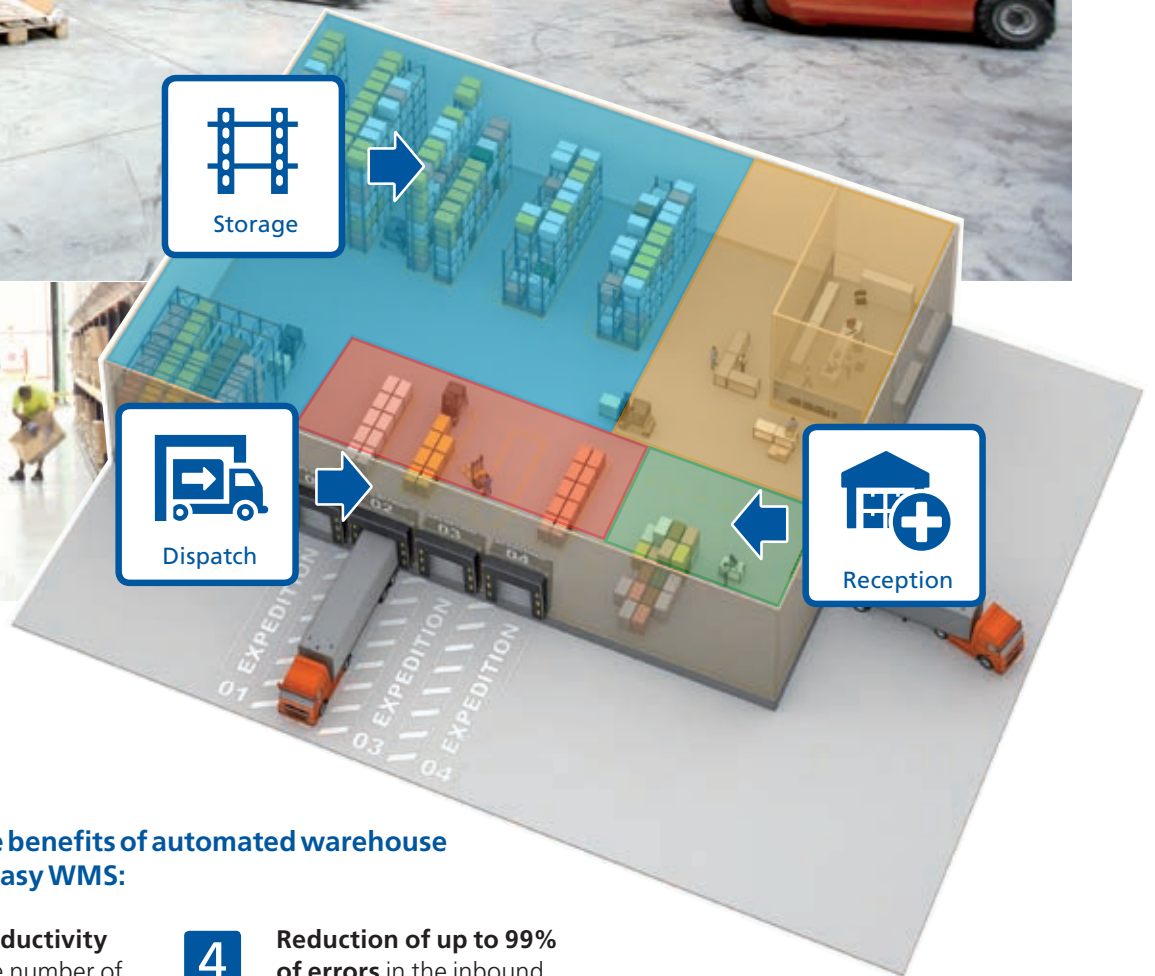

Here are some of the benefits of automated warehouse management with Easy WMS:

- 1** **Enhances productivity** and lessens the number of operations.
- 4** **Reduction of up to 99% of errors** in the inbound and outbound processing of material.
- 8** **Multi-proprietor, multi-warehouse and multilingual** functionalities.
- 2** **Storage capacity improved by up to 40%:** maximising the space occupied by goods in the warehouse.
- 5** **Control and optimisation of stock.**
- 9** **Ability to adapt to new market requirements** or trends, such as e-commerce.
- 3** **Increases the speed** of order preparation and dispatch.
- 6** **Real-time inventory** and traceability of goods.
- 10** **Improved document management.**
- 7** **Logistics cost reduction:** optimises human resources and handling costs.

For more information, request the Easy WMS catalogue or contact the sales department to ask for a demonstration or obligation-free advice.



HEAD OFFICE - SPAIN - Silici, 1 - 08940 Cornellà de Llobregat - Barcelona
Tel. +34 932 616 913 – info@mecalux.com – www.mecalux.com

EUROPE

BELGIUM

Tel. +32 2 346 90 71
info@mecalux.be
www.mecalux.be

CZECHIA

Tel. +420 222 524 240
info@mecalux.cz
www.mecalux.cz

FRANCE

Tel. +33 01 60 11 92 92
info@mecalux.fr
www.mecalux.fr

GERMANY

Tel. +49 (0) 2133 5065 0
info@mecalux.de
www.mecalux.de

ITALY

Tel. +39 02 98836601
info@mecalux.it
www.mecalux.it

NETHERLANDS

info@mecalux.co.nl
www.mecalux.co.nl

POLAND

Tel. +48 32-331 69 66
info@mecalux.pl
www.mecalux.pl

PORTUGAL

Tel. +351 21 415 18 90
info@mecalux.pt
www.mecalux.pt

SLOVAKIA

Tel. + 421 220 545 117
info@mecalux.sk
www.mecalux.sk

TURKEY

Tel. +90 216 706 10 15
info@mecalux.com.tr
www.mecalux.com.tr

UNITED KINGDOM

Tel. +44 0121 3336 602
info@mecalux.co.uk
www.mecalux.co.uk

AMERICA

ARGENTINA

Tel. +54 (11) 4006-4444
info@mecalux.com.ar
www.mecalux.com.ar

BRAZIL

Tel. +55 19 3809-6800
info@mecalux.com.br
www.mecalux.com.br

CHILE

Tel. +56 (2) 2827 6000
info@mecalux.cl
www.mecalux.cl

MEXICO

Tel. +52 (664) 647 22 00
info@mecalux.com.mx
www.mecalux.com.mx

PERU

Tel. +51 (1) - 323 4646
info@mecalux.pe
www.mecalux.pe

URUGUAY

Tel. +598 2683-8879
info@mecalux.com.uy
www.mecalux.com.uy

USA

Tel. 1-877-632-2589
info@interlakemecalux.com
www.interlakemecalux.com

