



# Drive-in Pallet Racking

Storage by accumulation: optimal use of available space





## General Features of the Drive-In System

**Drive-in racking is designed for the storage of homogenous products. It accommodates a large number of pallets for each SKU.**

This system makes better use of the available surface and height space than any other.

This type of installation is made up of a set of racking units that form inner loading aisles, with support rails for the pallets. The forklift trucks enter these inner aisles with their load held higher than the level at which it is to be deposited.

Each loading aisle has support rails on both sides. These are arranged on different levels and the pallets are placed on top. This racking system is made of extremely robust material, thus making it suitable for storing fully-loaded pallets.



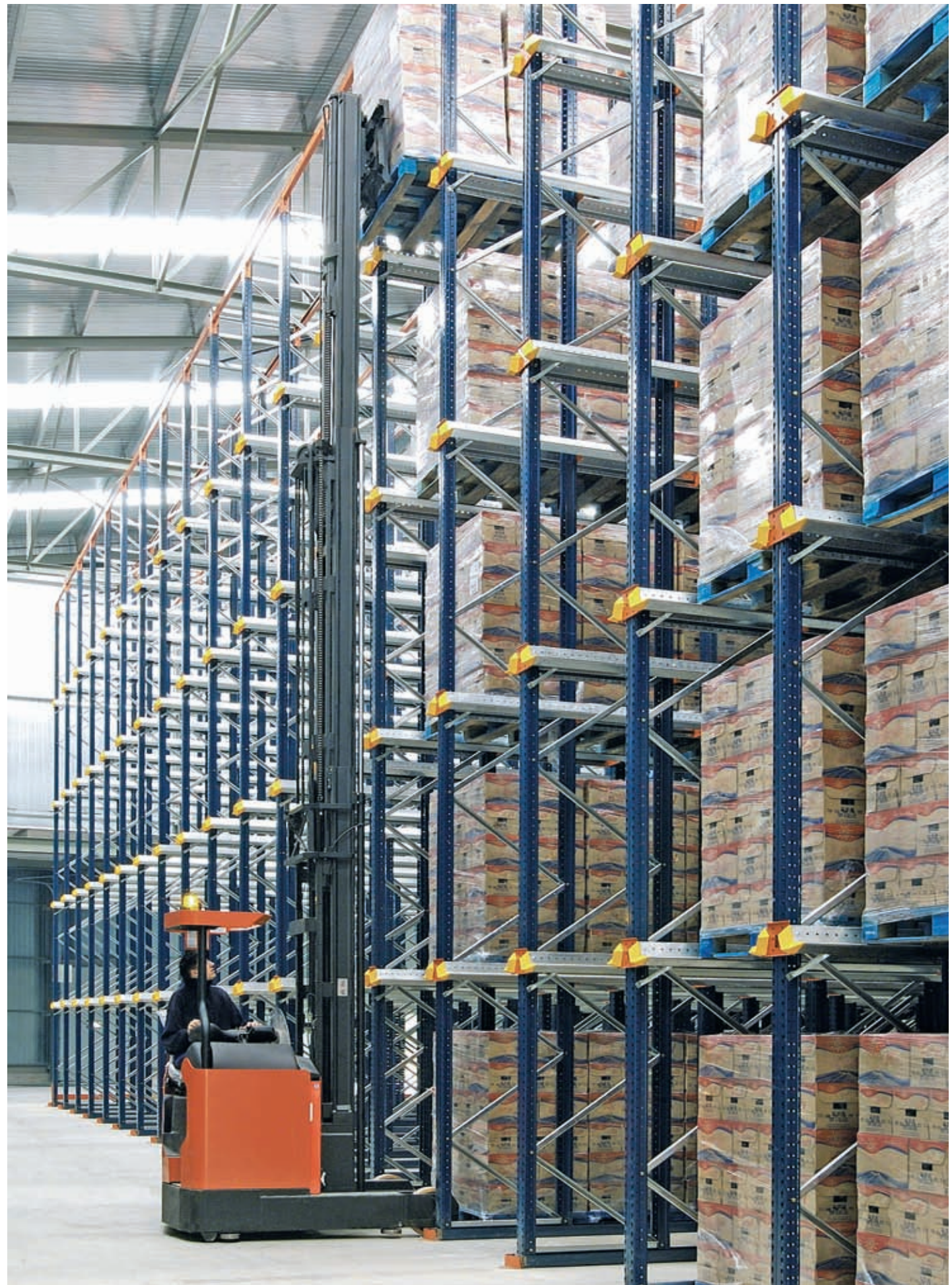

The drive-in system can accommodate as many SKU's as there are loading aisles. The number of pallets will depend on the depth and height of the loading aisles. It is advisable to store products with the same SKU in each loading aisle, in order to avoid unnecessary pallet manoeuvres. The depth of each aisle will depend on the number of pallets per SKU, the space available and the length of time they will be stored.

As shown in the following illustrations, the drive-in system has a greater storage capacity than the conventional pallet racking system. The illustrations show one facility with three different distributions and capacities.

**Conventional distribution**  
 Total surface area for storage: 858 m<sup>2</sup>  
 Capacity: 306 pallets per level

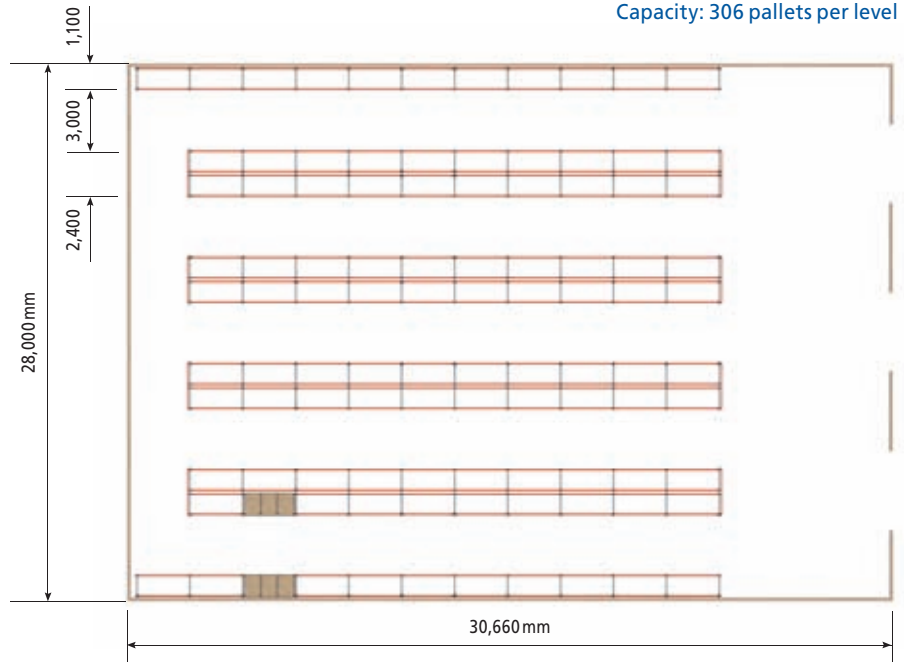

**Drive-in distribution**  
 Total surface area for storage: 855 m<sup>2</sup>  
 Capacity: 522 pallets per level

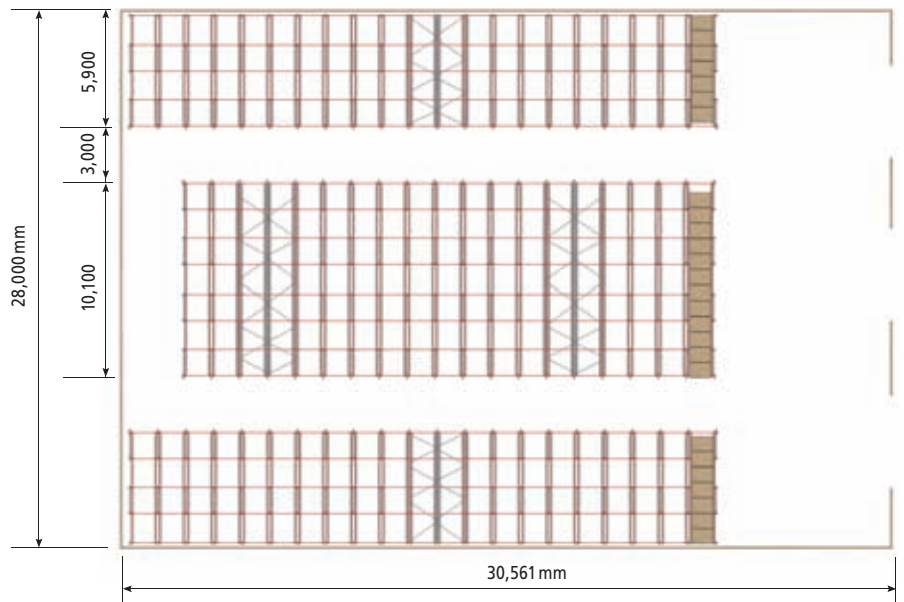



Conventional pallet racking and drive-in systems are usually combined in one warehouse. The drive-in system is used for products with a faster turnover.

Capacity: 383 pallets per level (200 pallets on drive-in system and 183 pallets on conventional pallet racking)

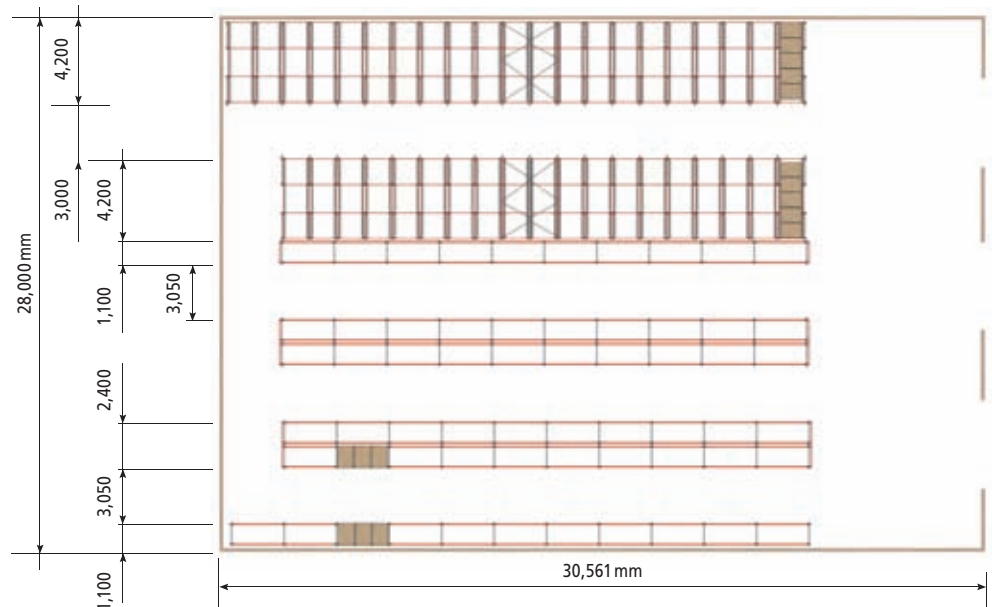



**Load management on a drive-in system**

**Drive-in**

This is the most common way of managing loads in a drive-in system. The racking units work like a warehouse depot. There is just one access aisle, from which loading and unloading are carried out in reverse order.

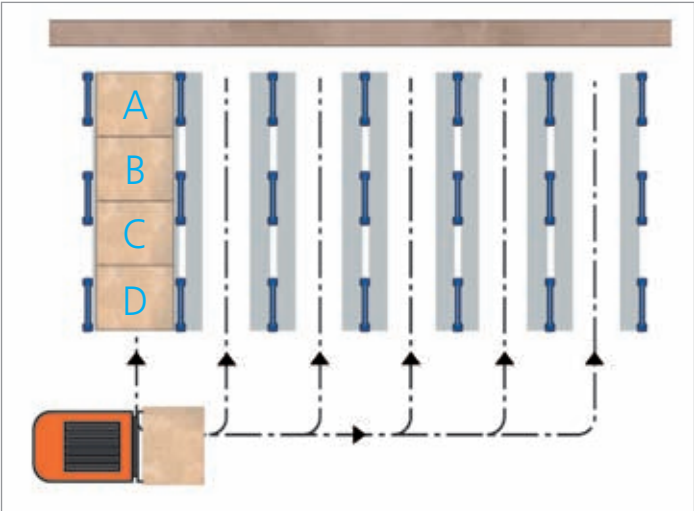

**Loading order:** A,B,C,D  
**Unloading order:** D,C,B,A  
LIFO system (the first load in is the last one out).

**Drive-through**

In this case, the load is managed using the racking unit as a controlling warehouse, with two load access points, one on each side of the unit. With this system, it is possible to control production differences, for example between manufacture and dispatch, between production phase 1 and phase 2, or between production and loading bays.

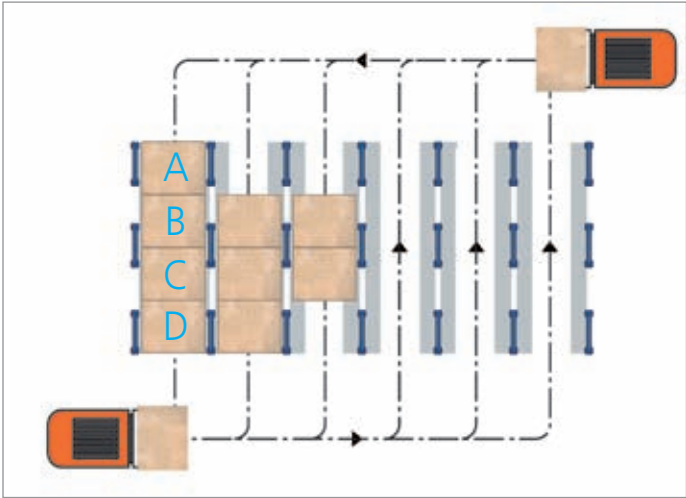

**Loading order:** A,B,C,D  
**Unloading order:** A,B,C,D  
FIFO system (the first load in is the first one out).





### Forklift trucks

The forklift trucks enter the storage aisles with their load held higher than the level at which it is to be deposited. Counter-balanced forklifts and standard reach trucks are the types used with drive-in systems.

Unlike the conventional system, the pallets are handled perpendicular to their stringers. In drive-in pallet racking, the forklift truck deposits the pallet by resting the stringers on the support rails. An extreme amount of pressure is exerted on the stringers, so the pallets used must be in very good condition.

The following illustrations show the correct way to place the pallets (figure 1).

Pallets can only be placed the other way around if they are strong and rigid enough, and if the weight of the load allows it.

If the load overhangs the pallet, dimensions A and B (the pallet measurements) may be different to A' and B' (the load measurements), which will influence the dimensions of the racking and supports, as shown in the pages relating to Clearances section (page 18).

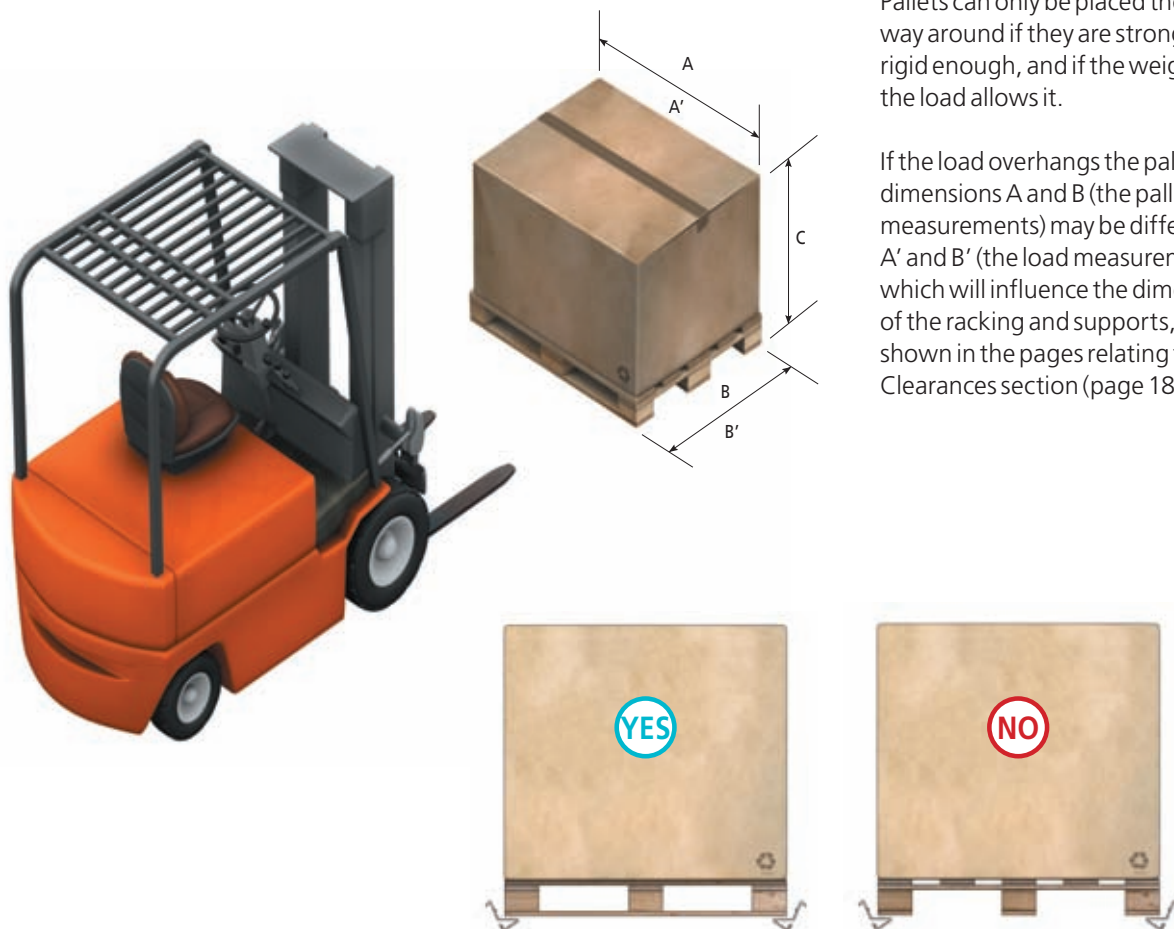

Figure 1





The forklift trucks travel along the insides of the storage aisles, so the necessary margins must be calculated in order to work safely. Certain measurements must be taken into account when designing an installation:

- A.** Total width of the forklift truck. There must be a minimum clearance between the forklift truck and the vertical elements of the racking units of 75 mm on each side. Dimension X, the distance between the uprights, must include this.
- B.** Operator's protection structure. A minimum clearance of 50 mm to the support rails is needed (dimension Y).
- CyD.** Height of the base and protection of the forklift truck. Dimension Z and dimension Y must be cleared comfortably.
- E.** Maximum elevation height. Must be at least 200 mm greater than dimension W.

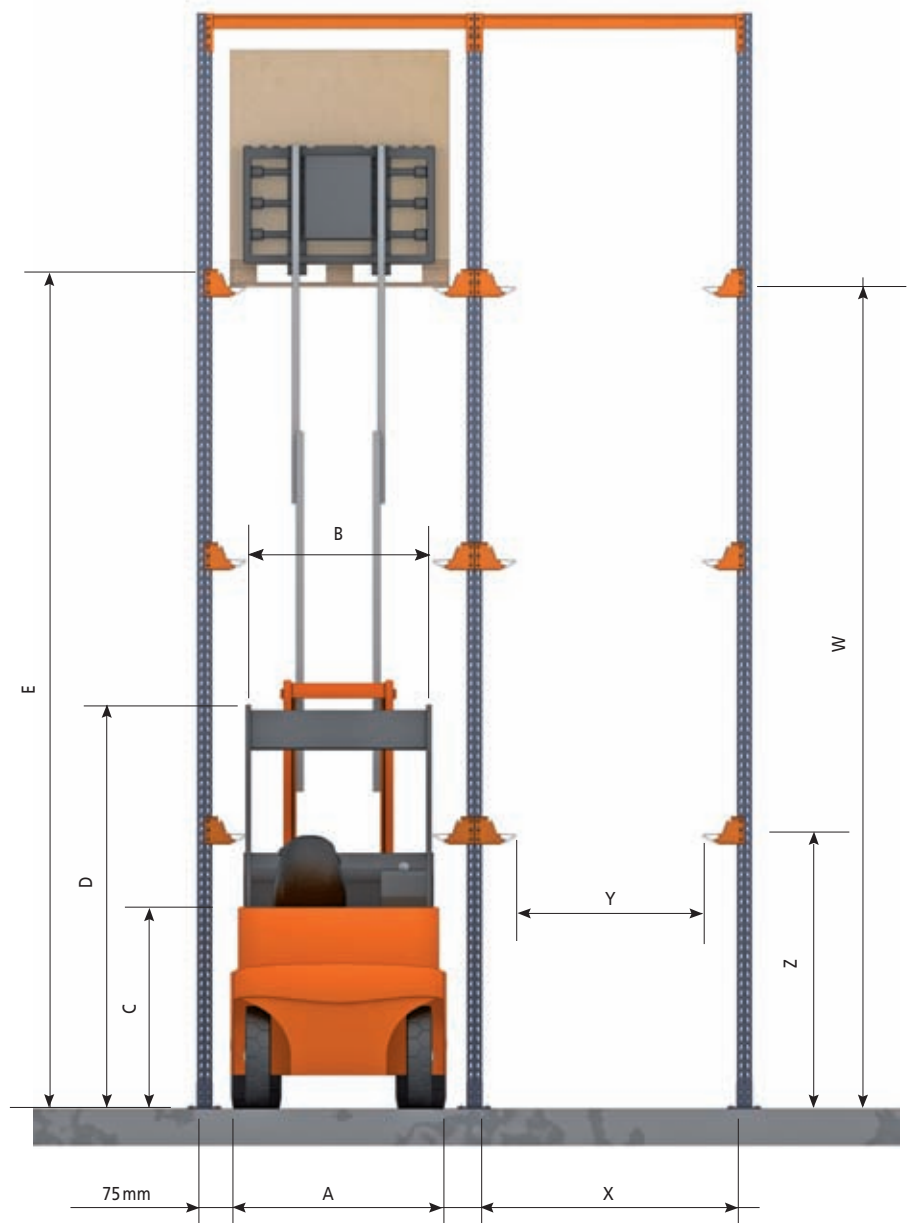



## Basis for Calculations

### Guidelines and recommendations

Mecalux calculates the compact racking units following the main criteria of:

- Eurocode 3
- FEM Directive 10.2.07 (Design of Drive-in Pallet Racking)

### Calculation criteria

Mecalux uses a powerful calculation program that implements the most important aspects of the above standards and recommendations, such as:

- Safety coefficients for both increasing loads and reducing material.
- Specific load situations for limit conditions and service conditions.
- Minimum pallet support on the 20 mm rail when the unit load is moved, considering the load condition that causes most deformity to the shelving.
- Second order calculation.
- Modelled structure with global and local imperfections.



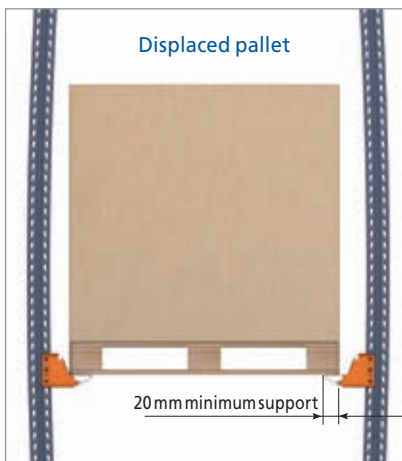
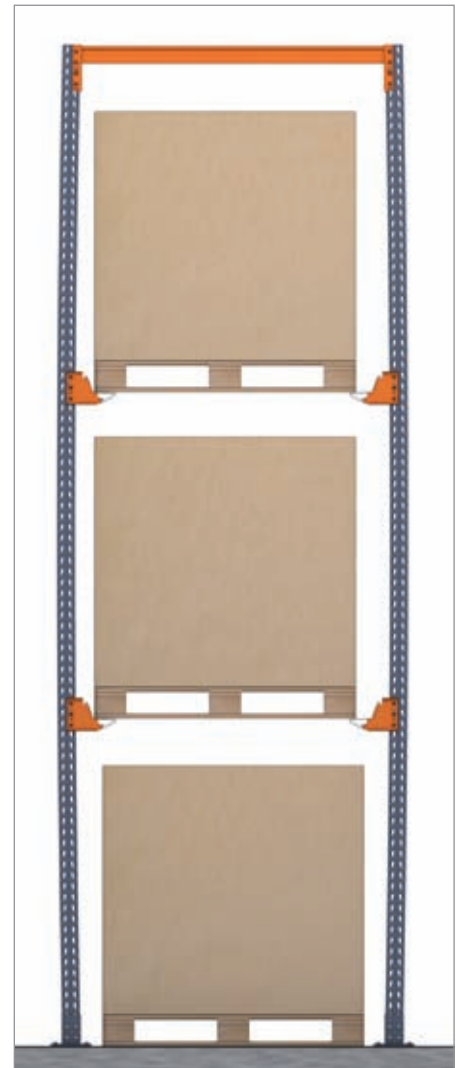

### Maximum deflection of the pallet support rails

The maximum deflection or deformation of the pallet support rail is limited to the distance between supports/200. As these are open profiles with non-symmetrical shapes, the rails are calculated using finite element programs.

### Safety factors

The structural safety of an installation is obtained by adopting the following coefficients:

- **Partial safety factors for loads** that increase the actions or loads to be considered. These coefficients vary according to the geographical area and may be 1.35, 1.40 or 1.50.
- **Partial safety factors for material** that reduce the characteristics of the materials used. These coefficients vary according to the geographical area and may be 1 or 1.10.



Figure 4. Example of a rail test for drive-in pallet racking.



### Racking unit stability

The racking units must provide guaranteed crosswise and lengthwise stability. The lengthwise plane is parallel to the frame and the crosswise plane is perpendicular to the storage aisles.

### Lengthwise stability

Stability is ensured by the rigidity of the frames and the diagonals and by their being attached to each other by the support rails themselves

### Crosswise stability

There are three basic construction systems that guarantee stability.

### Construction System 1

Rigidity is obtained by joining the uprights and beams together and the degree of embedding obtained between the feet of the uprights and the floor using two anchors.



Stability of the racking in construction system 1.



Stability of the racking in construction system 2 with single or double access.



### Construction System 2

As well as the aspects considered in construction system 1, stiffening aisles and upper cross bracing that transmit horizontal stresses straight to the floor are fitted.

### Construction System 3

The stiffening aisles are replaced by vertical bracing at the back (in single access racking units) or in the centre (in double access racking units).

The choice of construction system depends on the height of the racking units, the weight of the pallets, the depth of the aisle and use. Only construction systems 1 and 2 may be used with drive-through systems.



Stability of the racking in construction system 3.



### Calculating the uprights

The upright is one of the main elements of drive-in racking and must therefore be very carefully calculated. Unlike what happens with other storage systems, with racking of this type the upright is not only subjected to forces of compression but also of flexion, making it necessary to provide the upright with the necessary inertia.

Mecalux uses a powerful calculation program that implements the most important aspects of standard Eurocode 3 and the FEM Directive 10.2.07.

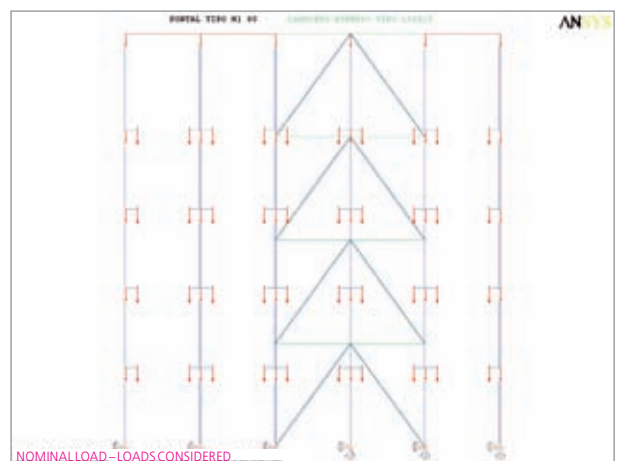
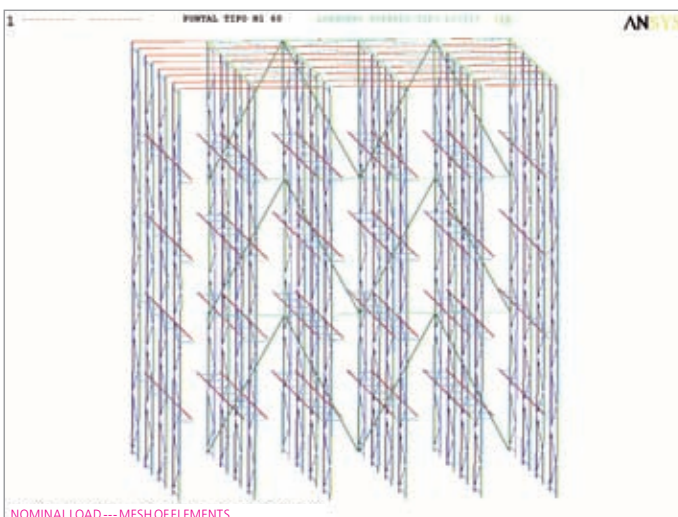

Figure 7. Load combination when calculating the upright.



The uprights obtained as a result of these calculations have been developed with geometries that are specific to each type of installation and cover all storage needs regarding height, load and distribution of the installation (figure 8).

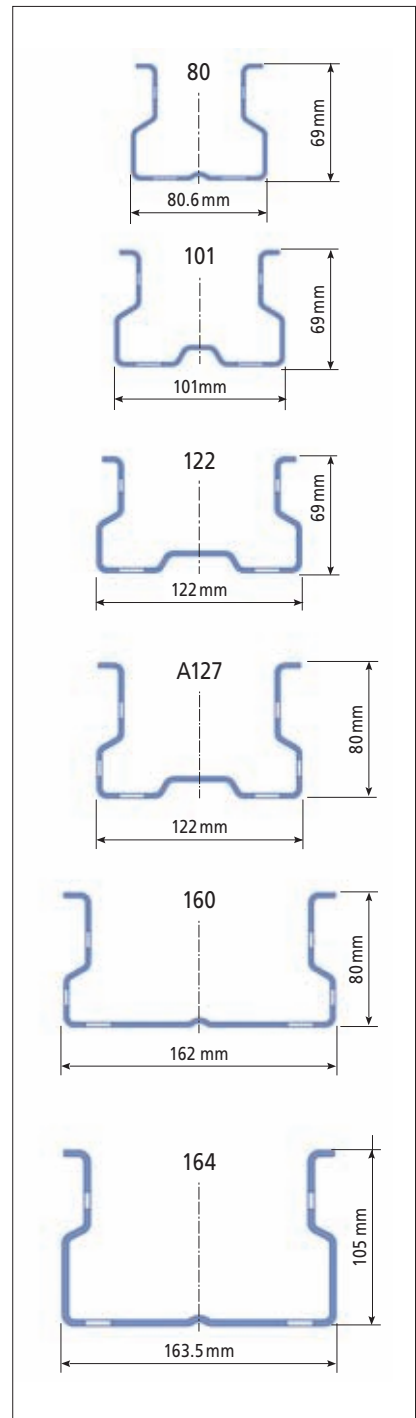
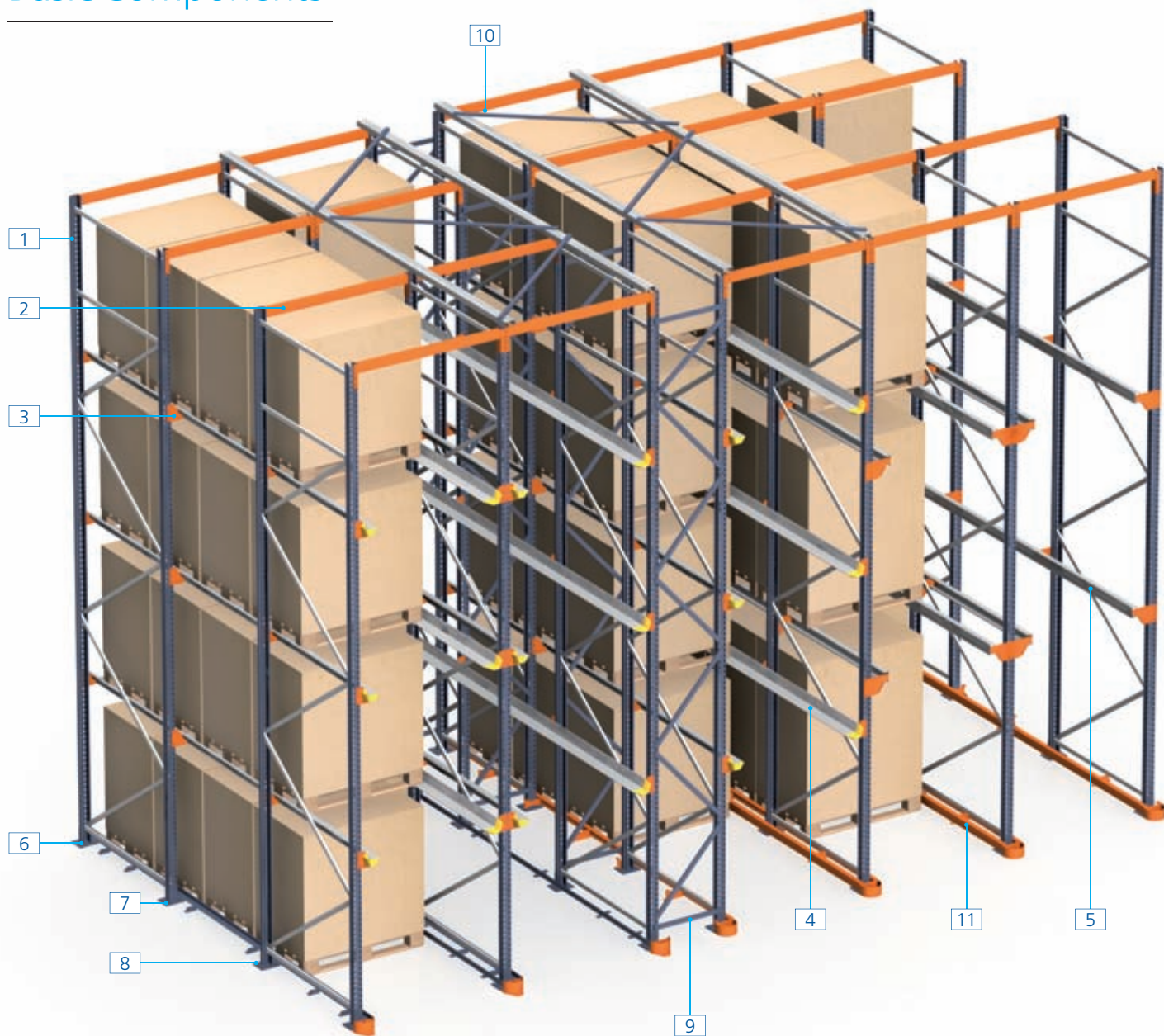

Figure 8. Uprights used.

## Basic Components



- |                      |   |
|----------------------|---|
| 1. Frame             | 7. Levelling plates                             |
| 2. Drive-in beam     | 8. Anchor bolts                                 |
| 3. Bracket           | 9. Bracing set (Construction system 1)          |
| 4. GP-7 rail         | 10. Upper cross bracing (Construction system 2) |
| 5. C-rail            | 11. Guide rail (optional)                       |
| 6. Upright footplate |   |





**Frames**

These are made up of two uprights with the corresponding horizontals and diagonals, footplates and accessories. The frames have slots every 50 mm to accommodate the beams and supports. The depth of the frame is determined by the dimensions of the storage aisle and the height, measurements and weight of the pallets.

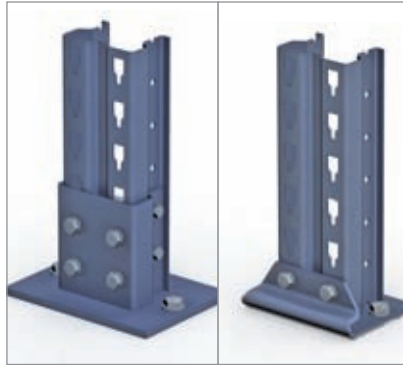

**Upright footplate**

This is part of the frame. It is designed to be fitted with two anchor bolts and the levelling plates.



**Top beam**

This connects the frames at the top, forming a gantry.

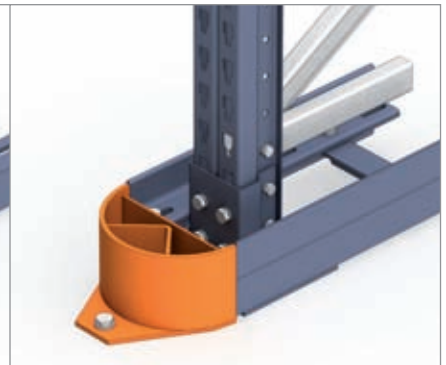

**Guide rails and protectors**

These make it easier for the forklift trucks to gain access around and reduce the possibility of accidental damage. These can be single or double profile, depending on the type of forklift truck used.



**GP-7 rail**

This is a pallet support profile, made of triangular-shaped galvanised steel. It enables pallet centralisation with minimal loss of space (50 mm). The profiles are supported on and joined to the uprights using GP-7 brackets.

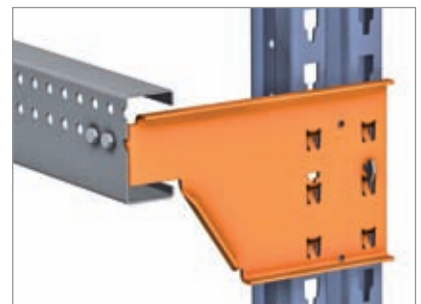

**C- rail**

Steel clad C-shaped 100 mm-high profile for supporting pallets without centralising. Used when the load overhangs the pallets. Supported on and joined to the uprights using C brackets.

# Clearances

## Construction system with a GP-7 rail

The GP-7 rail is ideal when all of the pallets to be stored are the same size. This means that the merchandise can be centralised and this prevents the pallets from colliding with the racking structure.

The fact that the GP-7 support is triangular in shape gives it a very high load capacity, with a loss in height of only 50 mm (the part of the profile that is under the pallet). This means that the space between levels can be reduced, or work tolerances increased (figure 1).

The aisle width is determined by the front measurement of the pallets plus the minimum necessary clearances. If the load overhangs the pallet, the aisle needs to be wider and the supports longer, as a minimum pallet support of 30 mm must be ensured when the pallet is completely displaced to one side (figure 2).

Figure 1

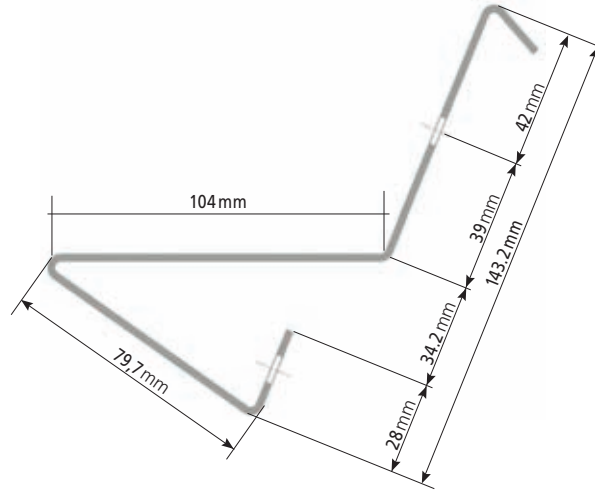

There is a minimum clearance of 75 mm. For high pallets, we advise increasing this tolerance level.

The frontal dimensions are calculated for pallets measuring 1200 mm along the front, at the base. The same criteria must be used for pallets of other sizes (figure 3).

Frontal dimensions (in mm)				
A	B	C	D	E
1,200	1,200	162	1,026	1,350
1,200	1,250	187	1,026	1,400
1,200	1,300	212	1,026	1,450
1,200	1,350	237	1,026	1,500
1,200	1,400	262	1,026	1,550

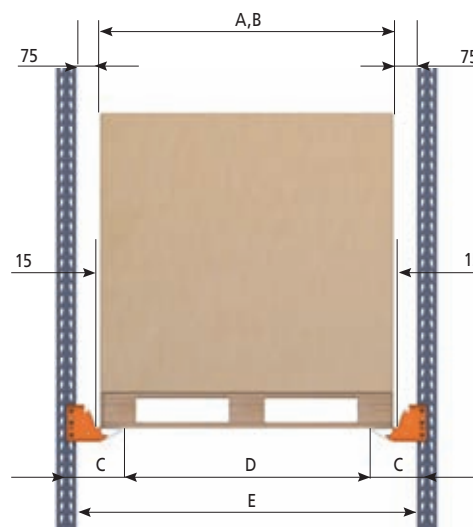

Figure 2. The load does not overhang the pallet.

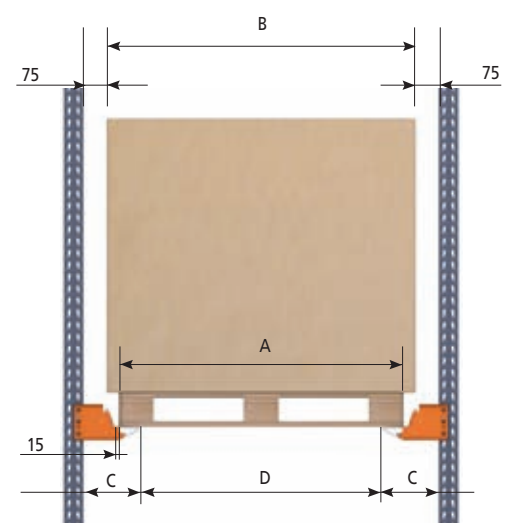

Figure 3. The load overhangs the pallet.

## Height

The minimum height measurements required are as follows:

- F: height of the lower and intermediate levels = height of the pallets + 150 mm
- G: height of the upper level = height of the pallets + 200 mm
- H: total height = at least, the sum of all the levels.

Dimensions F, G and H must always be multiples of 50 mm (figure 4).

## Depth

The minimum depth measurements to consider are the following:

- X: the total depth of all the pallets (including the measurement of the load if it protrudes) plus a clearance for positioning, which varies from 35 to 50 mm per pallet, depending on the number of pallets (the more the pallets there are the less the clearance required) (figure 5).

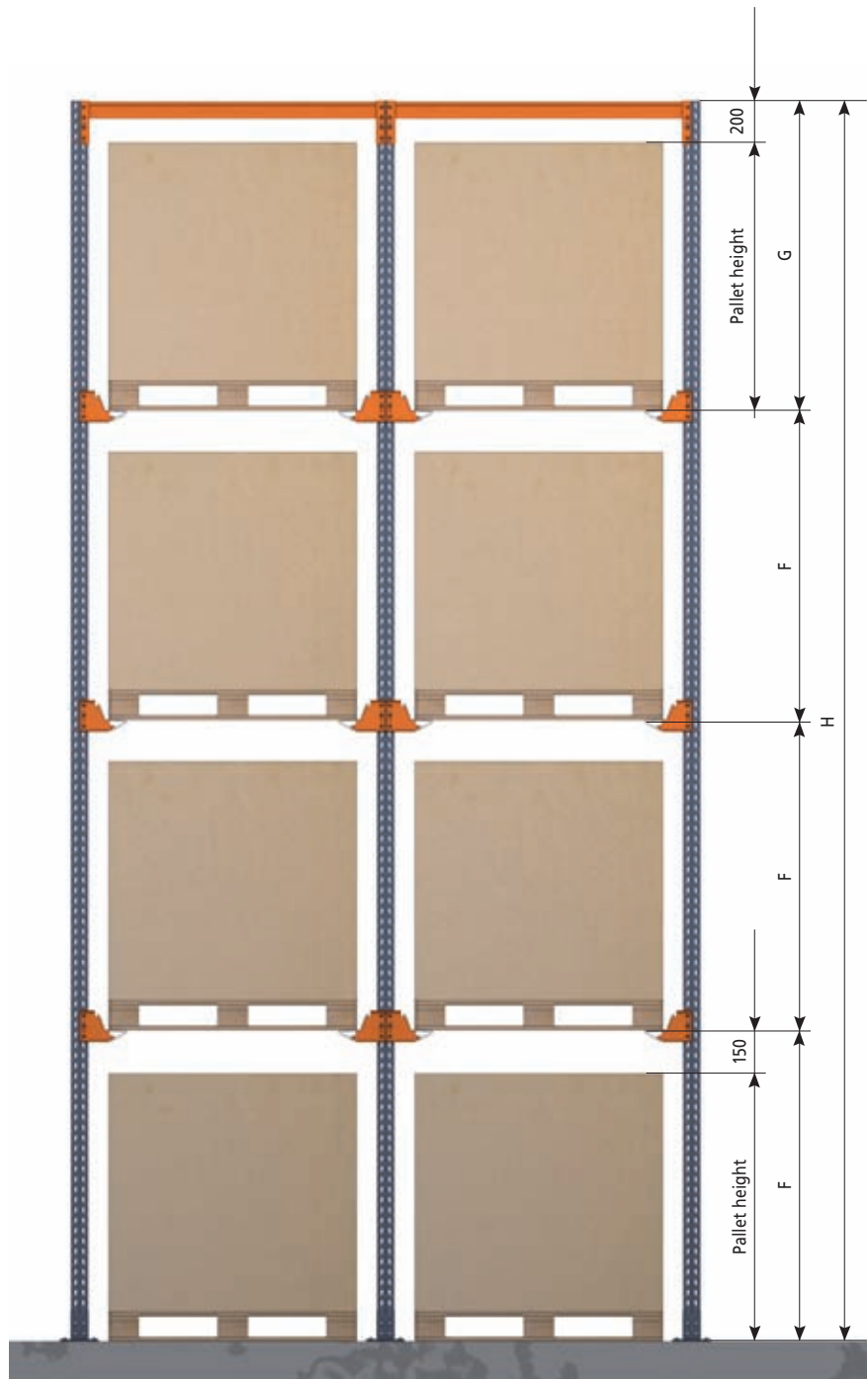

Figure 4

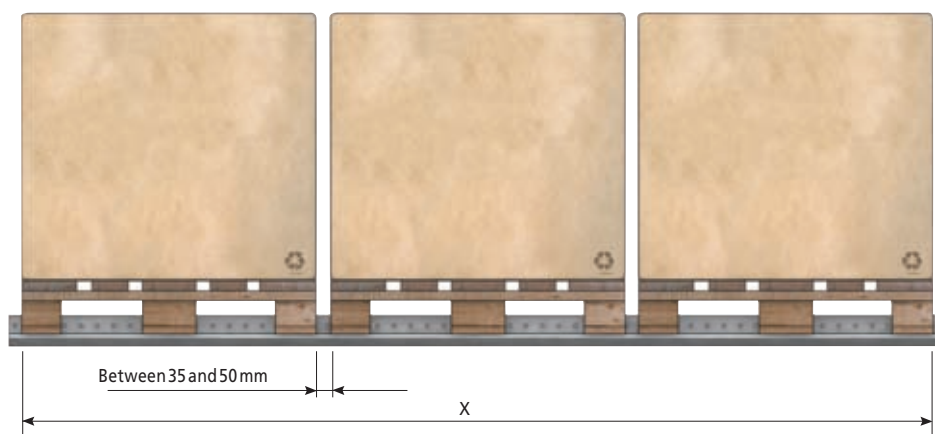

Figure 5

### Construction system with C-rails

This system is installed when the pallets used have different frontal measurements, and for very large storage units requiring greater support clearances.

With C-rails it is not possible to auto-centralise the different pallets that may be stored in an aisle. The system also means that the operators have to be more careful when manoeuvring forklifts (figure 6).

The pallets must be analysed before defining the support measurements.

The following illustrations show solutions for storing 1300 mm– and 1200 mm– wide pallets, where the load does not overhang the pallet in either case (figures 7 and 8).

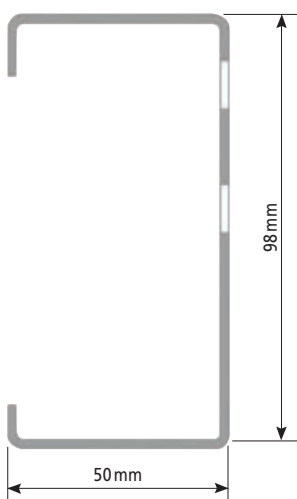
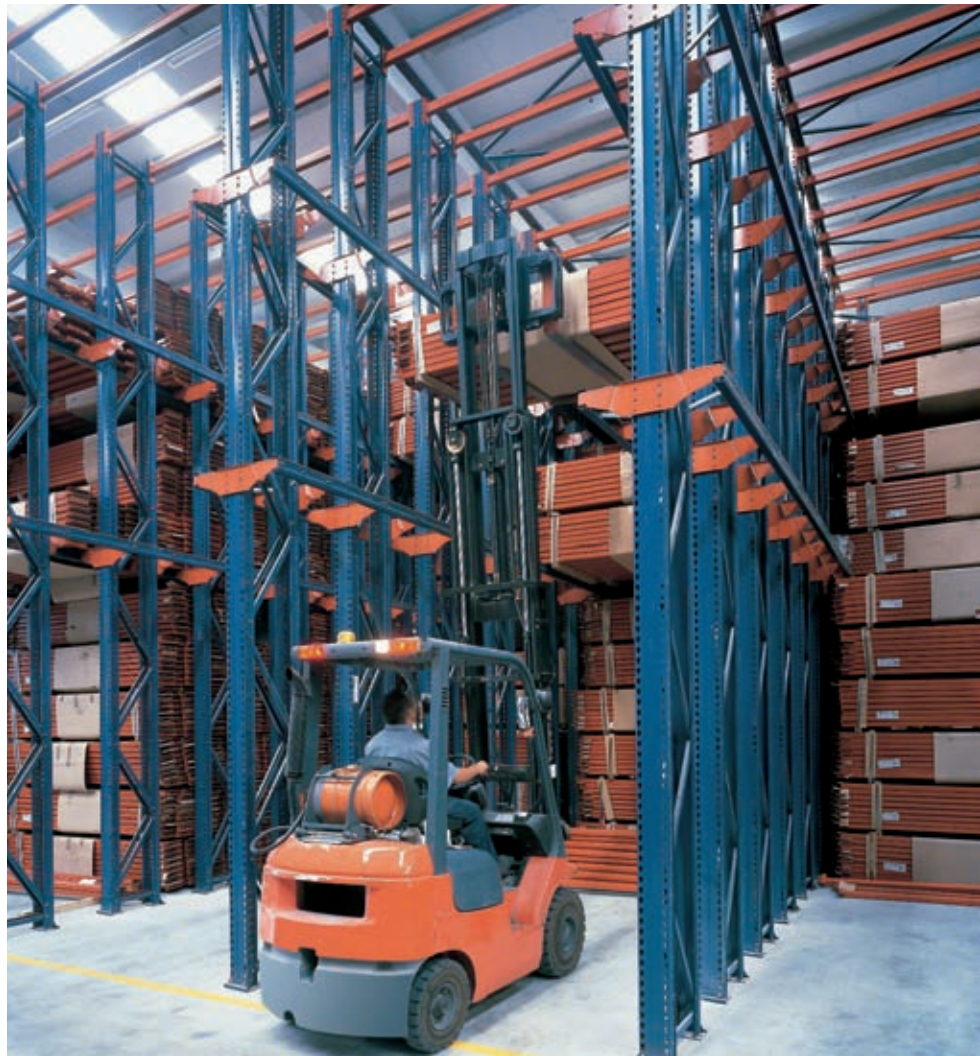

Figure 6

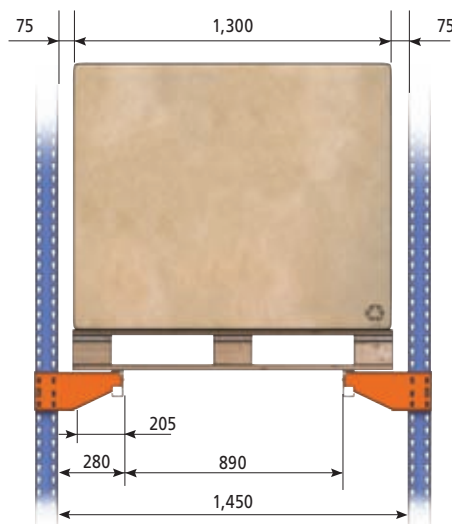

Figure 7

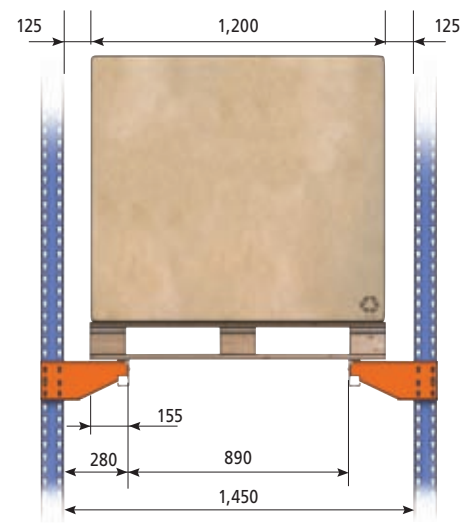

Figure 8



### Height

Height clearances to be taken into account are as follows:

- F: height of the lower and intermediate levels = height of the pallets + 300 mm.
- G: height of the upper level = height of the pallets + 200 mm.
- H: total height = at least the sum of all the levels.

Dimensions F, G and H must be multiples of 50 mm (figure 9).

For depth clearances, use the same criteria as for the GP-7 rail (figure 5).

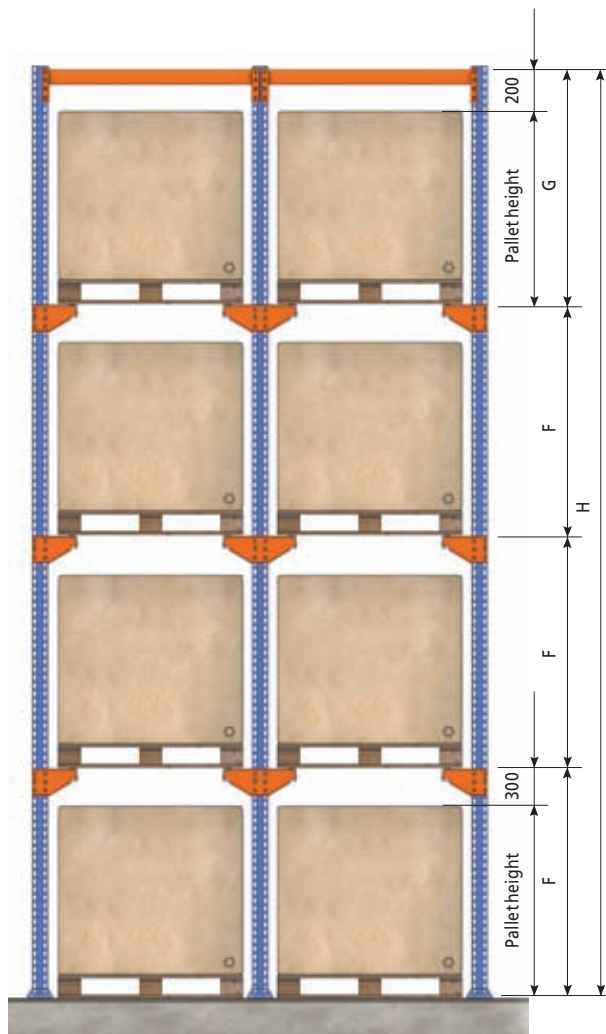

Figure 9

### Lower guide rails

The guide rail system is used to:

- Prevent the pallets colliding with the sides of the racking structure.
- Enable the forklift trucks to be equipped with side wheels so that they are centralised when moving inside the storage aisles.
- Avoid the risk of the racking being hit, preventing possible damage to the load and simplifying manoeuvres.

It is strongly recommended that they be fitted whenever very deep aisles are used.

Whenever guide rails are installed, it is important to bear in mind that the width of the aisle is calculated based on the distance the forklift needs to move, plus the width and clearances of the rail profiles.



The most common system is that which uses LPN50 profiles set onto supports that are fixed to the ground, with centralising protectors on the front of the shelving units. These are joined to the profiles and also anchored to the floor.

This system prevents shocks and vibrations being transmitted to the racking structure itself.

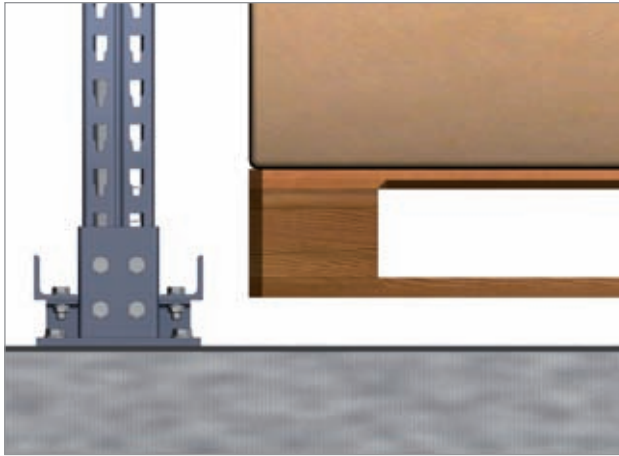

**Guided, with single profile**

The single-profile solution is sufficient when it is only necessary to guide the pallets.

The measurements between guides with LPN50 profiles and standard protectors are as follows:

Dimensions of the aisle with standard guides and protectors (in mm)	
X	Y
1,350	1,240
1,400	1,290
1,450	1,340
1,500	1,390
1,550	1,440

X: aisle width  
Y: distance between guides

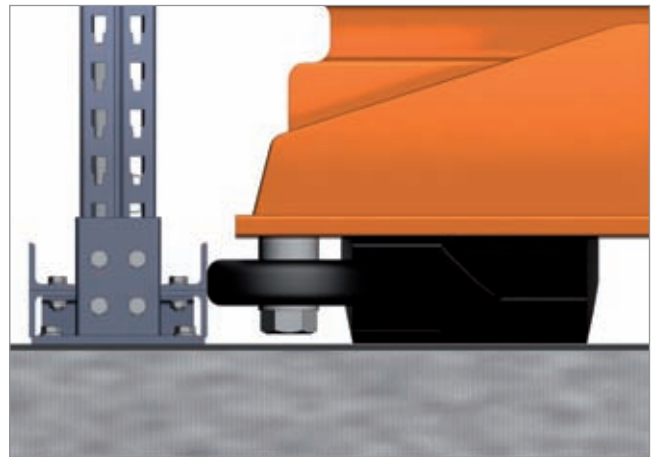
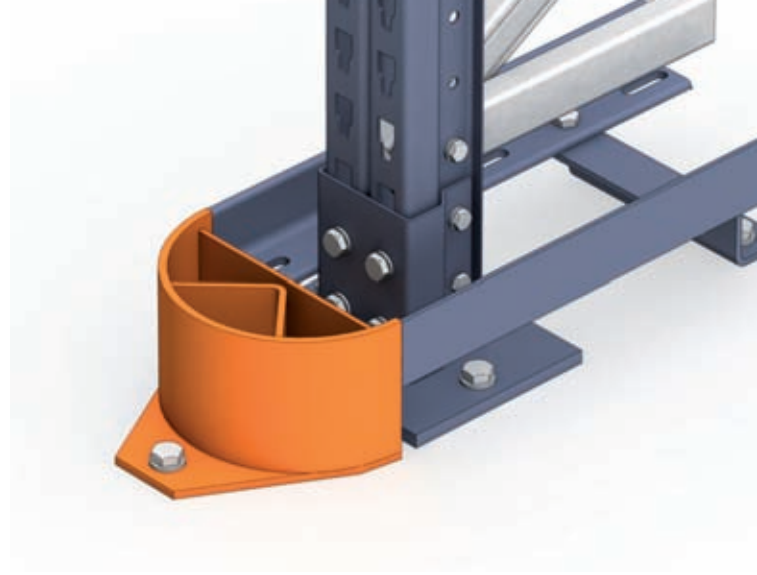

Another guiding system that can be used is with U-shaped profiles placed at the bottom of the racking uprights and held to the floor using the same anchor bolts.

This guiding system allows for greater separation between guides for wide-chassis forklift trucks, without the need for wider aisles. Front protectors can also be installed.

Specific analysis is required before a particular system is chosen.

**Guided, with double profile**

The double-profile solution is more common when the machine is guided with wheels and the dimensions and shocks they transmit make it essential.

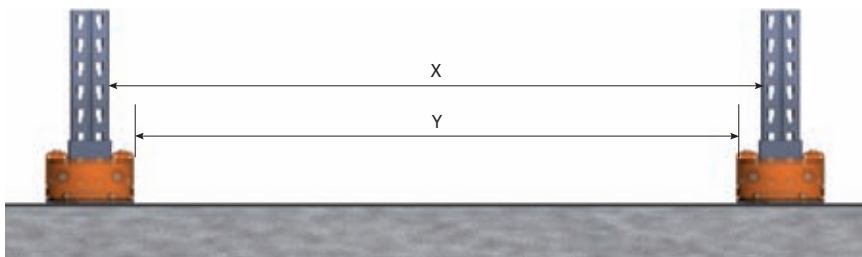



## Accessories

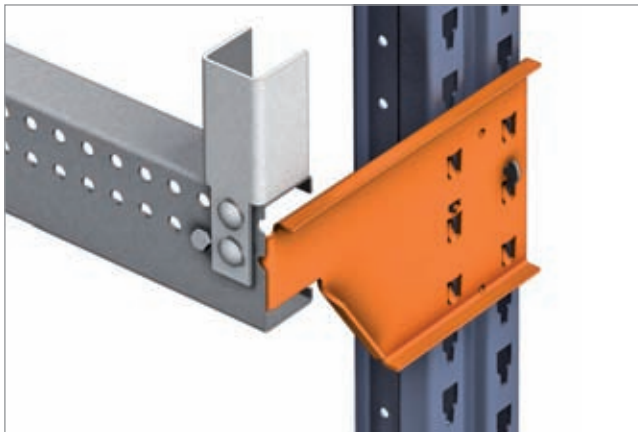

### C-rail stop

This is installed with C-type load rails. It has the same function as the GP-7 rail stops.



### GP-7 rail centralisers

GP-7 rail centralisers are installed at the end of GP-7 rails in each of the loading aisles of a compact pallet racking system.

These are very strong injected plastic parts which are attached to the ends of the front parts of the rails. They help to guide the pallet at the entrance to each aisle.





### Upright reinforcements

These are installed at the front of the first upright of each row of frames and provide protection against possible minor impacts.



### Loading signs

These signs describe the specifications of the installation, particularly the load capacity for which it was designed.



## Cold Chambers with a Drive-In System

---

This storage system is widely used in cold chambers – both refrigeration and freezing – where it is important to make maximum possible use of the space set aside for storage of products at a controlled temperature.



## Integral Warehouses with a Drive-In System



### Integral warehouses with a drive-in system

Drive-in pallet racking can also be used to build self-supporting warehouses. The main characteristic of these warehouses is that there is no need for an existing building, which translates into time and cost savings.

In installations of this type, the racking structure supports its own weight, the weight of the products stored in them and the corresponding additional forces, just like a traditional warehouse. In addition, they support the weight of the structure and protect against external forces (wind, snow, etc.)

These warehouses can be designed to store products at room temperature or as cold chambers.

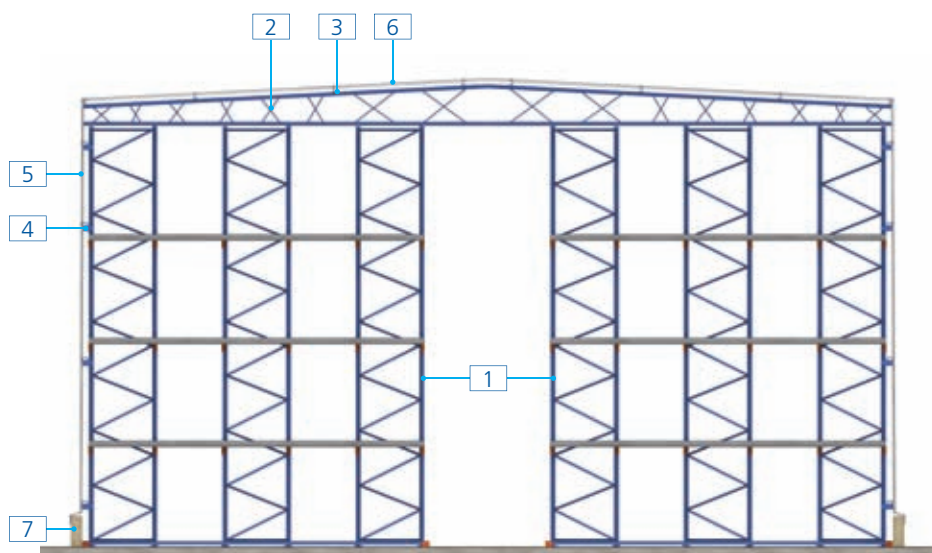

Section B-B'

1. Drive-in racking
2. Trusses resting on the racking structure
3. Roof joists
4. Façade joists
5. Façade cladding
6. Roof cladding
7. Watertight wall





## Automated warehouses with a drive-in system

In the compact storage system, stacker cranes can also be added, with a shuttle car moving on the load platform. The shuttle car, driven by a computer system managed by the warehouse, is responsible for depositing and extracting the pallets automatically. A shuttle and shuttle car assembly can also be installed on each level, thus considerably increasing the number of pallets moved.

Installations of this type need to be studied in great detail. Mecalux recommends that you request further information from our technical and sales department.





**easywms**

## Warehouse Management Software

Any warehouse containing palletised goods needs warehouse management software to provide total control and ensure its correct functioning. The software coordinates the goods from the start to the end, taking into account the specific criteria of each installation.

Easy WMS is a Warehouse Management Software that offers a wide range of functions to ensure efficiency in all areas and processes in the warehouse, bringing a saving in costs and improvements in the quality of the service.

The software is powerful, versatile and flexible; it optimises all operations relating to reception of goods, storage, order preparation and dispatches.

As well as being adaptable, Easy WMS is also capable of coordinating the management of several warehouses belonging to the same company, which share information and can transfer stock between themselves.

Mecalux, always aware of the high demands on industrial information technology, has created Mecalux Software Solutions, a department dedicated to programming, maintaining and updating Easy WMS.

For more detailed information about our warehouse management software and how it could benefit your business, ask for an assessment from one of our technical specialists.



Easy WMS offers various software modules which facilitate the integration of the software into any type of warehouse. The choice of module will depend on the individual requirements of each customer and the characteristics of their installation.



## Some of the many functions that Easy WMS has to offer

Easy WMS is simple-to-use warehouse management software that controls and optimises all logistics processes within a warehouse. The different functions of Easy WMS are based on the three main processes carried out within a warehouse:



### Reception

Reception processes include the arrival of goods into the warehouse coming from purchase from suppliers, from factory orders, from production or from returned items.

- ✓ Reception of goods with or without prior order.
- ✓ Reception of goods from supplier or entry of production orders.
- ✓ Recollection of logistics data.
- ✓ Partial receptions and product returns.
- ✓ Cross-docking.
- ✓ Standard and customised container labelling.
- ✓ Warehouse transfers.
- ✓ Automatic communication with ERP.



### Storage

Storage processes include determining the location, coordinating the correct placement and recording the storage of all goods received in the warehouse.

- ✓ Creating customised aisle and location strategies and rules.
- ✓ Precise or imprecise tracking.
- ✓ Permanent inventory.
- ✓ Stock adjustments and capability
- ✓ Manual and automatic stock replenishment.
- ✓ Stock below minimum level alerts.
- ✓ Items for different owners.
- ✓ Customised item labelling.
- ✓ Detailed warehouse map: aisle and location control.
- ✓ Allocating aisles by product turnover
- ✓ Warehouse control using customised meters.
- ✓ Guaranteed operations safety (standard LDAP).

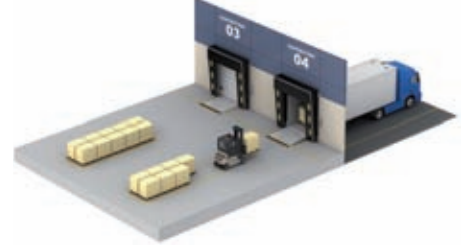

### Dispatch

Dispatch processes coordinate the goods leaving the warehouse, including putting together orders for customers, supplying materials to factories and transfer of goods between warehouses.

- ✓ Optimised searches, times and allocations.
- ✓ Advanced task interleaving system for a balanced work distribution,
- ✓ Grouping exit orders in different modes.
- ✓ Product-to-man and man-to-product:
  - . Optimising tasks based on the picking circuit.
  - . Creating picking areas.
  - . Dynamic picking location allocations based on needs.
  - . Picking with pick/put to light devices.
  - . Voicepicking.
- ✓ Strategic dispatching distribution (exit orders and routes).
- ✓ Possibility to dispatch alternative items.
- ✓ Dispatch labelling and documentation.
- ✓ Automatic communication with ERP.



**HEAD OFFICE - SPAIN** - Silici, 1 - 08940 Cornellà de Llobregat - Barcelona  
**Tel. +34 932 616 913 – info@mecalux.com – www.mecalux.com**

**EUROPE**

**BELGIUM**

Tel. +32 2 346 90 71  
info@mecalux.be  
**www.mecalux.be**

**CZECH REPUBLIC**

Tel. +420 222 524 240  
info@mecalux.cz  
**www.mecalux.cz**

**FRANCE**

Tel. +33 01 60 11 92 92  
info@mecalux.fr  
**www.mecalux.fr**

**GERMANY**

Tel. +49 (0) 2133 5065 0  
info@mecalux.de  
**www.mecalux.de**

**ITALY**

Tel. +39 02 98836601  
info@mecalux.it  
**www.mecalux.it**

**NETHERLANDS**

info@mecalux.co.nl  
**www.mecalux.co.nl**

**POLAND**

Tel. +48 32-331 69 66  
info@mecalux.pl  
**www.mecalux.pl**

**PORTUGAL**

Tel. +351 21 415 18 90  
info@mecalux.pt  
**www.mecalux.pt**

**SLOVAKIA**

Tel. + 421 220 545 117  
info@mecalux.sk  
**www.mecalux.sk**

**TURKEY**

Tel. +90 216 706 10 15  
info@mecalux.com.tr  
**www.mecalux.com.tr**

**UNITED KINGDOM**

Tel. +44 0121 3336 602  
info@mecalux.co.uk  
**www.mecalux.co.uk**

**AMERICA**

**ARGENTINA**

Tel. +54 (11) 4006-4444  
info@mecalux.com.ar  
**www.mecalux.com.ar**

**BRAZIL**

Tel. +55 11 4134-2155  
info@mecalux.com.br  
**www.mecalux.com.br**

**CHILE**

Tel. +56 (2) 2827 6000  
info@mecalux.cl  
**www.mecalux.cl**

**MEXICO**

Tel. +52 (664) 647 22 00  
info@mecalux.com.mx  
**www.mecalux.com.mx**

**PERU**

Tel. +51 (1) - 422 6060  
info@mecalux.pe  
**www.mecalux.pe**

**URUGUAY**

Tel. +598 2683-8879  
info@mecalux.com.uy  
**www.mecalux.com.uy**

**USA**

Tel. 1-877-632-2589  
info@interlakemecalux.com  
**www.interlakemecalux.com**

